PART 5 - NATIONAL ANNEX
ANNEX GB – France

C 160 NG TRANSALL

<u>Subject</u>	<u>Paragraph</u>
C 160 NG Transall	1GB
AAR equipment	2GB
Refuelling Heights and Speeds	2GB a
Maximum Transferable Fuel	2GB b
Fuel Transfer Rate	2GB c
Regulated Fuel Pressure	2GB d
Fuel Type Available for AAR	2GB e
Receiver Type Certified	2GB f
C 160 Lighting	2GB g
Exterior Lighting	2GB g (1)
AAR Equipment Signal Lights	2GB g (2)
Mark Facilities	2GB h
Dimensions	2GB i
RV Aids	2GB j
List of Appendices	3GB

1GB C160 NG Transall. The new generation of C 160 type aircraft has a probe for receiving fuel from drogue equipped tankers. Some have both tanker and receiver capabilities.

2GB AAR equipment. The C160 has one fuselage refuelling station; the hose drum unit is fitted internally in the extended left main landing gear pod. The hose is 27.5 m (90 ft) long and terminates in an Inter technique MA-3 type coupling and drogue (for hose extern length and drogue, see [appendix 4](#)).

a. Refuelling Heights and Speeds. The AAR height band is sea level to 18,000 ft and the speed range is 160 to 220 KIAS. The operating speed to extend the hose is 180 KIAS. Below 5,000 ft, meteorological conditions may influence the hose stability. AAR below 1,500 ft AGL has to be approved first by French authorities.

b. Maximum Transferable Fuel. Transferable fuel is dependent on sortie duration; maximum transferable fuel is 14,000 kg (30,870 lb).

c. Fuel Transfer Rate. The transfer rates are:

1. Maximum 1200 kg/min (2650 lb/min or 1500 l/min);
2. 600 kg/min (1330 lb/min or 750 l/min) ;
3. Minimum 400 kg/min (880 lb/min or 500 l/min).

d. Regulated Fuel Pressure. Fuel pressure at the drogue is regulated not to exceed 3.5 bars (50 ± 5 psi).

e. Fuel Type Available for AAR:

- (1) Primary/usual fuel is F34.
- (2) Alternate fuel - information not supplied.

f. Receiver Types Certified. The aircraft types cleared to refuel from the C160NG are listed in Annex GD.

g. C 160 Lighting.

(1) **Exterior Lighting.** The C160 has the following exterior lighting: anti-collision lights (red) on the top of the fin and under the right main landing gear pod, engine nacelle and underwing floodlighting, receiver aircraft flood lights and electroluminescent lines on the left main landing gear pod. See [Appendix 1](#).

(2) **AAR Equipment Signal Lights.** AAR equipment signal lights are mounted in vertical rows next to the left landing gear box hose tunnel. Lights are coloured amber, green and red, see [Appendix 2](#). The lights signal the following:

Steady Red:	Do not make contact
Steady Amber:	AAR system ready for contact
Steady Green:	Fuel flows
Red (whilst in contact):	Breakaway

h. Mark Facilities. Fuel dump through hose.

i. Dimensions. See aircraft drawing. [Appendix 3](#).

j. RV Aids. The C 160 NG has the following radio, navigation, and RV aids:

- (1) VHF, UHF and HF radios.
- (2) VOR, TACAN, ADF, GPS, INS, and search/weather radar.
- (3) TACAN (A/A Mode, range available), Radar (beacon mode), and AIRTAC (Airborne Beacon equivalent to on-ground TACAN : Receiver selecting TACAN - T/R Mode, same channel as the tanker, will obtain heading and distance to the tanker).

3GB. List of Appendices :

<u>Appendix</u>	<u>Subject</u>
Appendix GB-1.	C 160 - Exterior Lighting
Appendix GB-2.	C 160 - AAR Equipment Signal Lights and Hose Markings
Appendix GB-3	C 160 Transall
Appendix GB-4.	C160 Hose and Drogue

**PART 5 - NATIONAL ANNEX
ANNEX GB, APPENDIX 1 - FRANCE**

C160 – EXTERNAL LIGHTNING

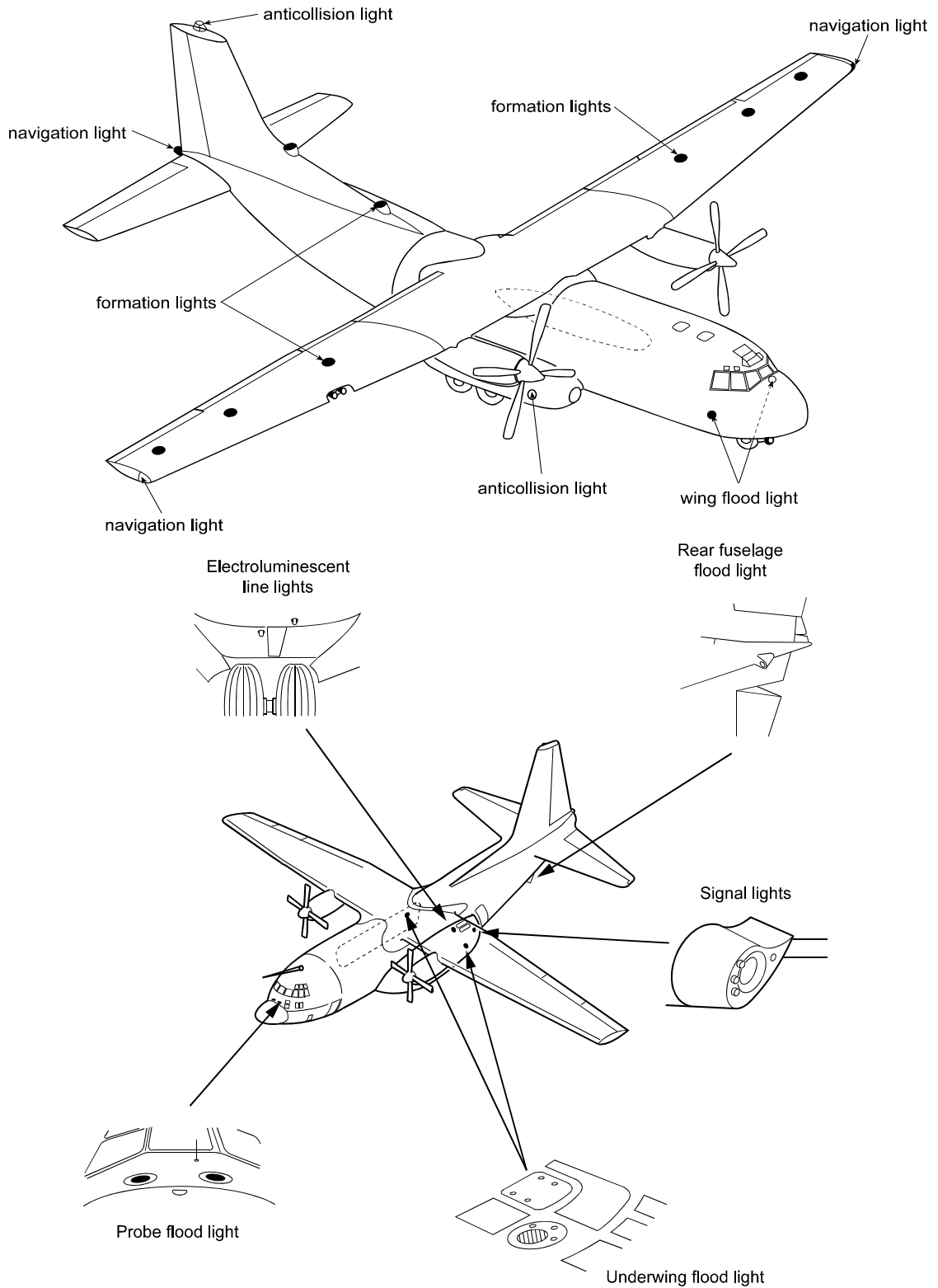

INTENTIONALLY BLANK

**PART 5 - NATIONAL ANNEX
ANNEX GB, APPENDIX 2 – France**

C160 – AAR Equipments Signal Lights and Hose Markings

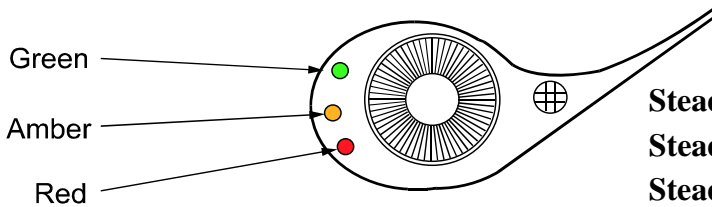
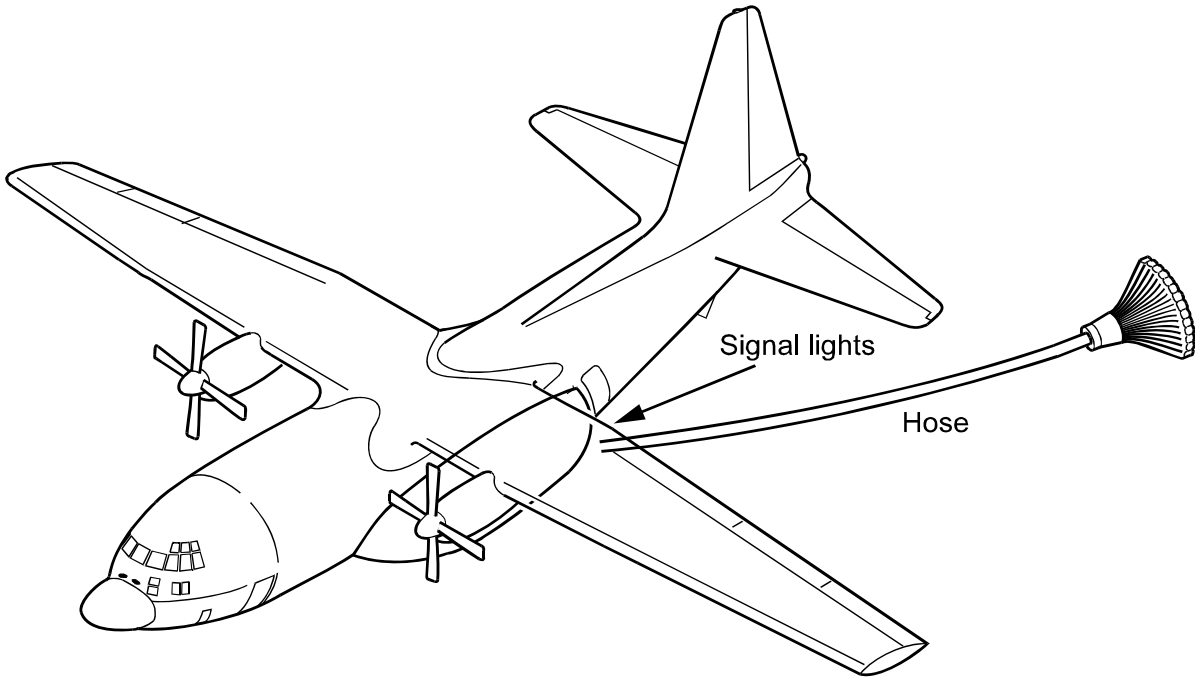

- Steady Red:** Do not make contact
- Steady Amber:** AAR system ready for contact
- Steady Green:** Fuel flows
- Red (whilst in contact):** Breakaway

Hose markings

8.65 m : fuel regulation zone

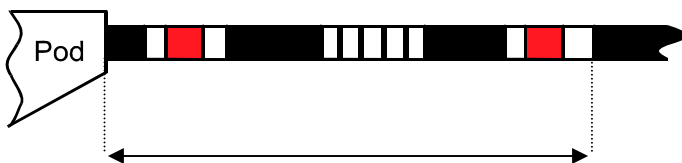

13.50 m : hose regulation zone

INTENTIONALLY BLANK

**PART 5 - NATIONAL ANNEX
ANNEX GB, APPENDIX 3 – France**

C160 – Dimensions

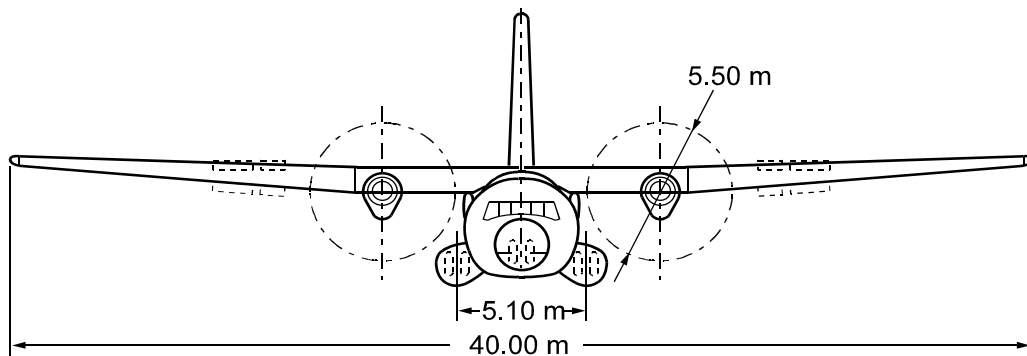
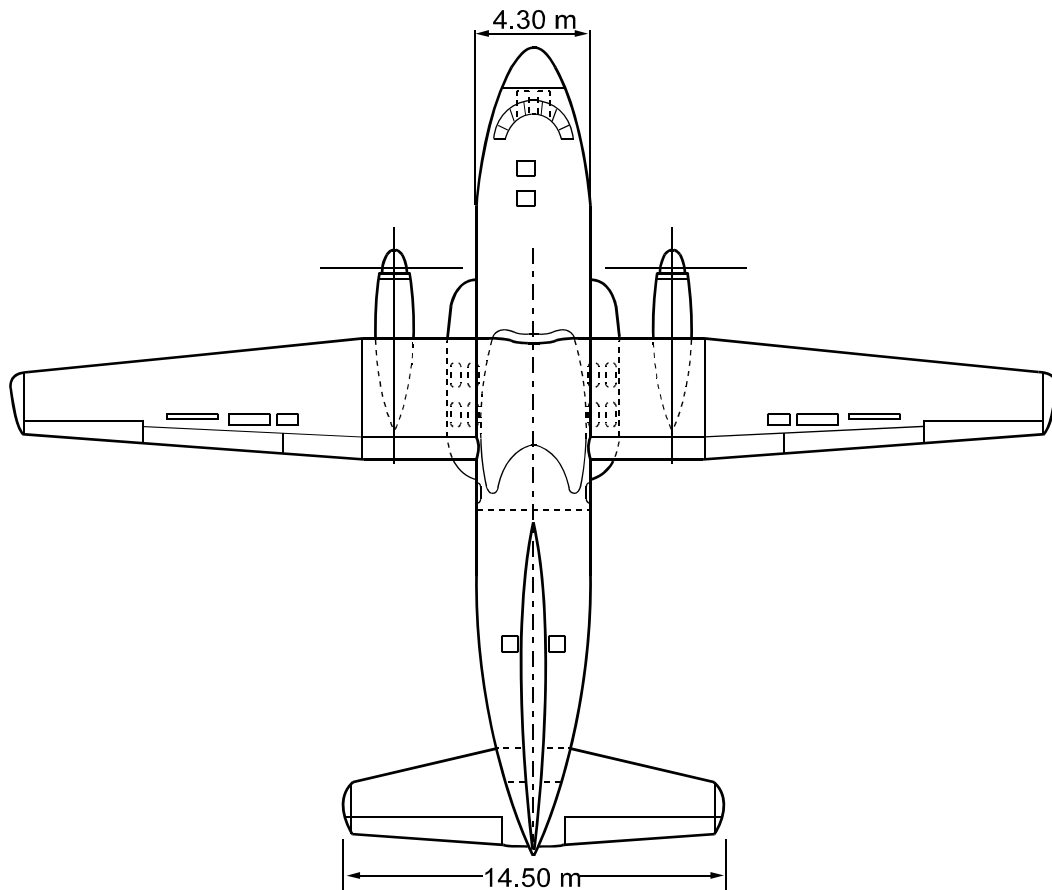
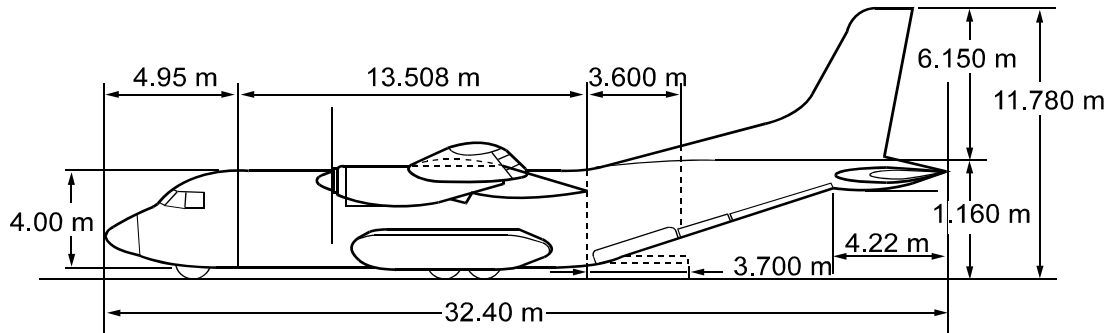

INTENTIONALLY BLANK

**PART 5 - NATIONAL ANNEX
ANNEX GB, APPENDIX 4 – France**

C160 – Hose

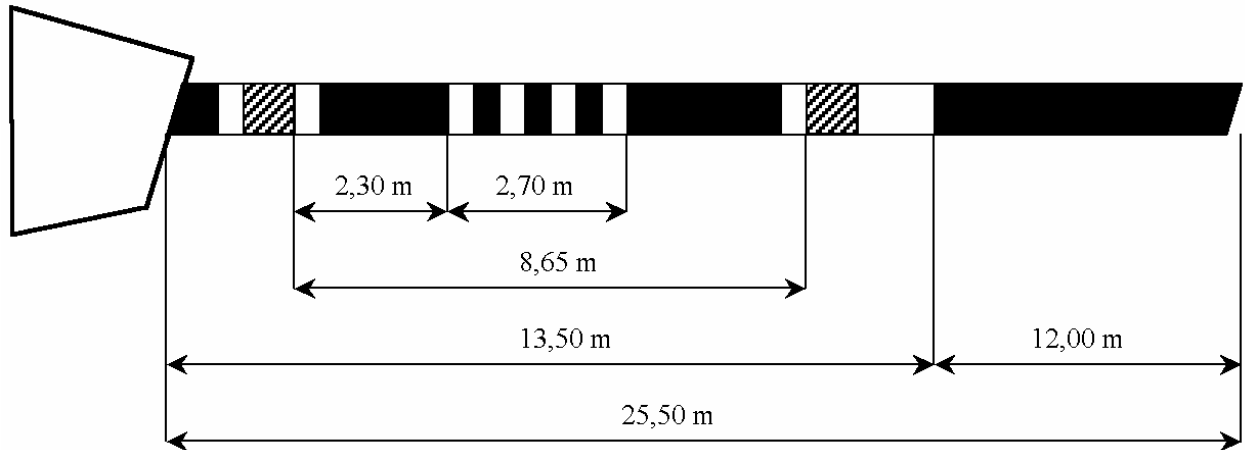

C160 – Type of Drogue

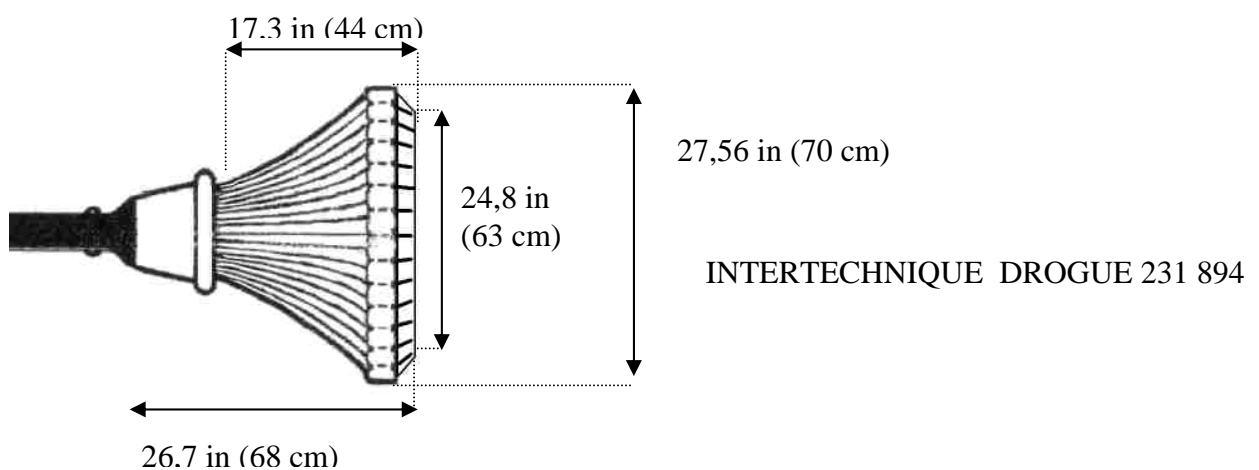

INTENTIONALLY BLANK