

# RAFGSA COMPETITION TRAINING WEEK NOTES

<b>CONTENTS .....</b>	<b>1</b>
<b>CROSS COUNTRY FLYING - CLIMBING.....</b>	<b>3</b>
REJECTION PRINCIPLE.....	3
CENTRING.....	3
<i>Entering .....</i>	<i>3</i>
<i>Which Way to Turn .....</i>	<i>3</i>
<i>Building the Picture .....</i>	<i>3</i>
<i>Centring Technique.....</i>	<i>4</i>
<i>Points to Watch.....</i>	<i>4</i>
<b>THERMAL FORMATION.....</b>	<b>5</b>
THE AIRMASS.....	5
<i>Stability.....</i>	<i>5</i>
<i>Instability.....</i>	<i>5</i>
HEATING THE AIR.....	5
THERMAL SHAPE.....	6
<i>Triggering.....</i>	<i>6</i>
<i>Vortex Ring.....</i>	<i>6</i>
<i>The Core.....</i>	<i>6</i>
EFFECT OF WIND.....	6
<i>Wind Strength.....</i>	<i>6</i>
CYCLING.....	7
<i>Factors .....</i>	<i>7</i>
<b>FINDING YOUR THERMAL.....</b>	<b>9</b>
TERRAIN EFFECTS.....	9
<i>Fixed Source in Light Wind.....</i>	<i>9</i>
<i>Pulsing in Stronger Wind .....</i>	<i>9</i>
WIND SHEAR.....	9
<i>Wind Gradient near the Ground.....</i>	<i>9</i>
<i>Wind Shear at Altitude.....</i>	<i>10</i>
LIFT ALIGNMENT.....	10
<i>Requirements for Streeting.....</i>	<i>10</i>
<i>Importance of Sun's Position.....</i>	<i>10</i>
HEIGHT BANDS AND FLYING TECHNIQUE.....	11
<i>Top Height Band .....</i>	<i>11</i>
<i>Middle Height Band .....</i>	<i>11</i>
<i>Lower Height Band.....</i>	<i>12</i>
<b>USING THERMALS .....</b>	<b>13</b>
THERMAL STRUCTURE .....	13
AIDS TO LOCATING THE CORE .....	13
ENTERING THE THERMAL .....	14
<i>Lifting and Tilting.....</i>	<i>14</i>
<i>Edge of Thermal – Minimal Lift, Maximum Tilt.....</i>	<i>14</i>
<i>Midway Between Edge and Core – Moderate Lift and Tilt.....</i>	<i>14</i>
<i>Head-on to Core – Max Lift, Min Tilt.....</i>	<i>14</i>
PULLING UP.....	14
STAYING IN THE CORE.....	15
ANGLE OF BANK.....	15
CONCLUSION .....	15
<b>CROSS COUNTRY FLYING - GLIDING.....</b>	<b>16</b>
CRUISING.....	16
OPERATING BANDS.....	16
SUMMARY.....	18

<b>SPEED TO FLY</b> .....	<b>19</b>
BASIC SPEED TO FLY THEORY .....	19
WHAT IS THE RATE OF CLIMB?.....	19
WHICH RATE OF CLIMB?.....	19
SPEED RING SETTING.....	20
FOLLOWING THE ENERGY .....	20
SUMMARY.....	20
<b>FIELD LANDINGS</b> .....	<b>21</b>
<b>PROCEDURE AFTER A COMPETITION LANDOUT</b> .....	<b>24</b>
<b>COMPETITION DOS AND DON'TS</b> .....	<b>23</b>
<b>VARIOMETER SYSTEMS</b> .....	<b>25</b>
PURPOSE.....	25
IMPLEMENTATION .....	25
UNITS.....	25
THE VANE TYPE VARIOMETER.....	25
<i>Operation</i> .....	25
<i>Capacity &amp; Static</i> .....	26
<i>Errors</i> .....	26
<i>Pilot's Serviceability Checks</i> .....	26
THE ALTITUDE DERIVATIVE VARIOMETER (ELECTRIC).....	26
<i>Audio</i> .....	26
<i>Repeater Units</i> .....	26
<i>Modes Available</i> .....	27
<i>Using Cruise</i> .....	27
<i>Theory of Cruise</i> .....	27
<i>Ground Test</i> .....	27
THE 'NET' VARIOMETER.....	27
<i>Introduction</i> .....	27
<i>Purpose</i> .....	27
<i>Using The Netto Variometer</i> .....	28
<i>Theory Of Netto</i> .....	28
TOTAL ENERGY - THE IRVING TUBE.....	28
<i>Purpose</i> .....	28
<i>Irving Tube</i> .....	29
<i>The Total Energy Tube</i> .....	29
<i>Airspeed</i> .....	30
<b>ABOUT THE L-NAV</b> .....	<b>31</b>
CONTROL RULES .....	31
THE L-NAV DISPLAY SCREENS .....	31
<b>USING THE EW BAROGRAPH</b> .....	<b>36</b>
<b>POSITIONING FOR TURNING POINT PHOTOGRAPHS</b> .....	<b>ERROR! BOOKMARK NOT DEFINED.</b>
<b>ASSESSMENT OF TURNING POINT PHOTOGRAPHS</b> .....	<b>ERROR! BOOKMARK NOT DEFINED.</b>
EQUIPMENT .....	<b>ERROR! BOOKMARK NOT DEFINED.</b>
PERSPECTIVE EFFECTS.....	<b>ERROR! BOOKMARK NOT DEFINED.</b>
FINDING THE GLIDER.....	<b>ERROR! BOOKMARK NOT DEFINED.</b>
BRIAN PRATT'S METHOD .....	<b>ERROR! BOOKMARK NOT DEFINED.</b>
MISCELLANOUS INDICATIONS .....	<b>ERROR! BOOKMARK NOT DEFINED.</b>
THE COMPLETE POSITION.....	<b>ERROR! BOOKMARK NOT DEFINED.</b>
OTHER METHODS .....	<b>ERROR! BOOKMARK NOT DEFINED.</b>
CHOICE OF TURNING POINTS.....	<b>ERROR! BOOKMARK NOT DEFINED.</b>

## CROSS COUNTRY FLYING - CLIMBING

1. The very experienced cross country pilot will generally select the thermal he thinks he will climb in next a long way down track. He then glides for that thermal, following a route to pass through as many smaller thermals as possible, without diverting too far off track. Only if one of the thermals he passes through turns out to be exceptional will he stop before reaching his selected cloud.

### REJECTION PRINCIPLE

For the inexperienced pilot, however, it is better to work on a rejection than on a selection principle. Decide whether the thermal is not the right one to climb in by looking for reasons why you should not climb. If there is a reason why you should not climb then pass on to the next thermal. What reasons can there be for not climbing in this thermal?

- Is it below the minimum strength I have decided to accept?
- Is the next thermal likely to be stronger than this one?
- Can I reach the next thermal without risk?
- Will it take a long time to centre? (hitting them in the middle saves a lot of time).
- Considering my height and the thermal strength, am I unable to justify the time spent circling?

2. It is a common fault to stop and climb too often and so progress very slowly. If you were only to stop in one thermal in three and climb 2,000 ft, rather than three times to climb 650ft, you only have to centre once, saving considerable time.

### CENTRING

3. Centring techniques vary to suit individual experience and glider type; the type of thermal must also be taken into account. There is a technique that is particularly quick and simple which is not explained in most gliding books. The technique is based on the pilot's ability to interpret physical sensations, ie changes in G load and any rolling sensations not induced by the pilot. These sensations are caused by what are commonly referred to as surges. Flying into an area of more rapidly rising air increases the G load that the pilot will feel through his bottom; also there is generally a change in the noise of the airflow over the glider, due to the increased airspeed, and a nose-down pitching of the glider may be noted with strong lift.

#### Entering

4. When entering the thermal it is important to be fairly relaxed. If you are tense your energy will be consumed stretching the rudder cables and crushing the stick. This makes it very difficult to sense the small surges through the airframe and the controls that will enable you to centre quickly. The tension is probably the principal reason why it seems difficult to centre when low.

#### Which Way to Turn

5. Having flown into a thermal and decided to climb your first problem is which way to turn. Given a tendency for the glider to roll either way, resist it, and roll against the direction of the surge. A carefully chosen approach to the thermal will enable you to forecast which way to turn before you get there. If there are no obvious indications then turn in the direction you find most comfortable.

#### Building the Picture

6. Aim to build up a picture in your mind of the thermal and your position in it, using the variometer and any turbulence or airspeed fluctuations. In Fig 2 we have entered the thermal and turned right, we find ourselves circling to one side of the strongest lift. As we turn, we will fly out of the strong lift and then back into it. As we enter the area of increasing lift the G will increase and we will feel a surge.

- Moderate angle of bank during first turn to establish lift pattern
- Tighter turn resulting from increasing the bank when passing through the surge of the stronger lift.
- Angle of bank reduced to the optimum for climbing. If still not centred repeat B and C.

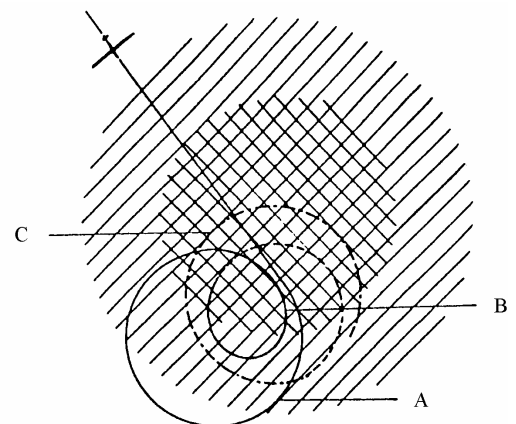
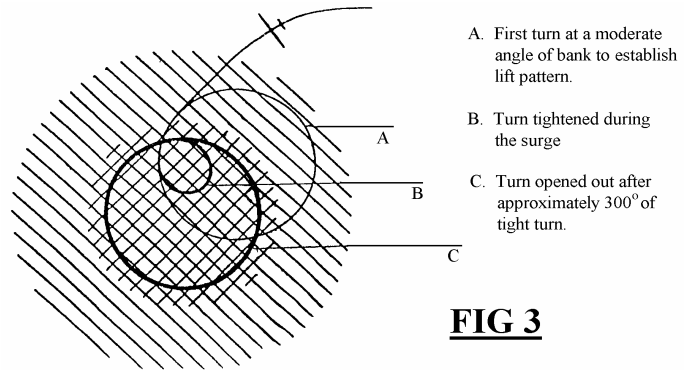

**FIG 2**

### Centring Technique

7. As soon as the surge is felt, roll on more bank until you are turning quite tightly. This has the effect of placing the centre of our turn nearer to the centre of the lift. But we are now probably turning steeper than the optimum for the best rate of climb. In some cases however, it may be correct to maintain the new steeper turn particularly if you are into the core of the thermal. If we are now turning steeper than necessary or we are still not centred correctly, then take one 360 turn to reduce the bank. Do not straighten up and roll back into the turn or take the bank off suddenly. Try to reduce the bank keeping the centre of the new turn in the same place as the centre of the tighter turn. If you have done this properly you should find yourself nearer to the centre of the lift or maybe even in the centre. If still not absolutely centred then when you feel the surge of the core, tighten the turn again.

8. Repeat this until you are established in the core of the thermal, with the correct angle of bank. With some practice you may find that you can centre using this method in two turns. A further refinement is to tighten the turn upon feeling the surge, opening out the turn after about 300°, as in Fig 3. This does require more skill however, and it is likely to take longer to centre if done badly.



**FIG 3**

### Points to Watch

9. Inaccurate flying will probably preclude you from mastering these, or any other techniques, so we ought to look at some of the points to watch when centring.

a. When rolling into the turn do not allow the speed to increase as this will result in an elliptical turn when you slow down.

b. Remember the tail of the turn, between deciding to turn and establishing the turn there is a delay - the results shown in Fig 4. Allowing the speed to increase when rolling into the turn will lengthen the tail.

c. When reducing or increasing bank always use sufficient rudder to balance the aileron drag.

d. Only make smooth positive control movements not small jerky movements.

e. Only move the controls when necessary.

f. If you are having to hold off bank excessively all the way round the turn, ensure you are using the correct amount of rudder. If you are, then you may well be flying too slowly.

g. Avoid flying slower than minimum sink speed, or flying faster than is necessary to maintain good control.

h. Do not turn so steeply that you cannot turn at a reasonable speed and still maintain control.

i. If a surge tries to roll you further into your turn do not resist this but tighten the turn and open out after about 270°.

j. If a surge tries to roll you out of the turn resist the surge and if possible tighten the turn.

k. Monitor the rate of movement of the vario needle as this information is as valuable as the actual reading.

l. Ignore fluctuations in airspeed, fly by attitude with reference to the ASI occasionally.

m. Look up as well as all round, you may see a better part of the cloud, as well as another glider climbing faster.

n. Learn to relate the airflow noise with changing lift strength and inaccurate flying, etc, so you can look out more.

o. Use other gliders circling as you would a cumulus cloud. It is only an indication of lift, not that the lift is good (unless the glider is flown by the National Champion).

p. Keep a sharp lookout for soaring birds, either in your thermal or close by. Watch their relative vertical motion - they are usually a reliable indicator of good lift, especially swallows and swifts, which feed on the insects in the thermal core.

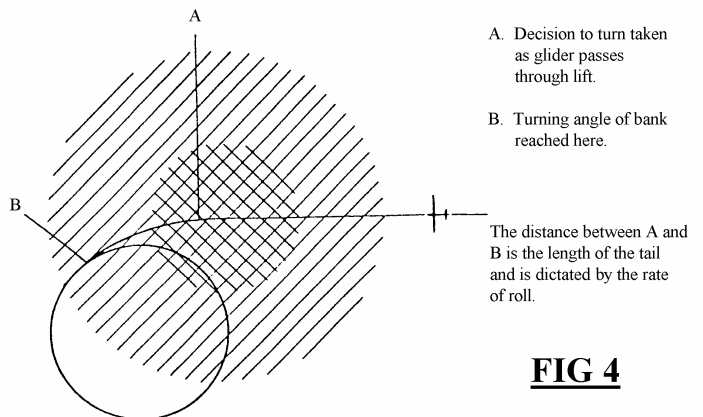

**FIG 4**

## THERMAL FORMATION

1. In order to soar on a very good day it is not necessary to understand what is happening in the air around you; it is possible to find lift by accident, relying on luck to simply bump into thermals. However, if you wish to fly cross-country and soar on typical days, you will need to learn what to look for and how to best use the lift you find.
2. The task of explaining what to look for and how to find lift will be greatly simplified if you understand the process involved in the formation of a thermal and its structure. It is not possible to cover every facet of thermal structure here and further explanation and background can be obtained in "Meteorology for Glider Pilots" by C E Wallington.
3. Confidence in both the thermals and your ability to find them is essential for successful cross-country soaring. There is a tendency to feel that the thermals are "will-o'-the-wisp" characters and once set upon by a glider are destroyed by the weight and turbulence. Of course sometimes they are impossible to climb in but this is usually because they are too small or you have hit one at the wrong time. A good thermal is a massive movement of air, weighing several thousand tons. In comparison with this, the mass of a glider is relatively insignificant. What causes this massive movement of air? The sun warms the ground, and the air closest to it will then rise; if the airmass is unstable the warmed air will continue to rise until its temperature becomes the same as the surrounding air. We need to look into this process a little more deeply if we are to broaden our understanding of thermals.

### THE AIRMASS

4. The difference in temperature between the air in the thermal and the surrounding air is the factor which governs the strength of the lift.
5. As the thermal rises the pressure decreases and it will expand. This causes a loss of temperature, called adiabatic cooling. The rate at which the air will cool as it rises is known as the Dry Adiabatic Lapse Rate (DALR); this is 3°C per 1000 ft., conversely as air descends it warms at 3°C per 1000 ft. In order for the air to continue to rise when warmed, the temperature gradient within the airmass must be greater than 3°C per 1000 ft.

#### Stability

6. In Fig 1 you can see what would happen to a parcel of air warmed to 21°C in an airmass with an ambient surface temperature of 20°C. If the rate at which the airmass (ie surrounding air) cools equalled the dashed line, at 2°C per 1000ft, then the parcel of air would reach the same temperature as its surroundings at 1000ft, suppressing any tendency to rise further. *The airmass is stable.*

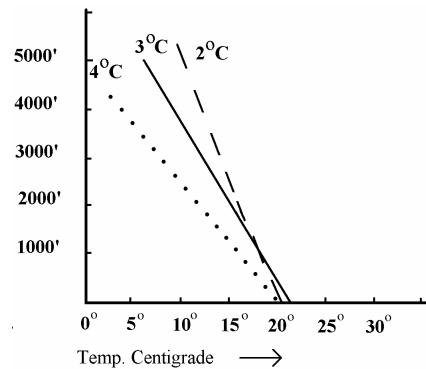

**Fig 1**

----- equals a temperature gradient of 2°C per 1000 ft  
..... equals a temperature gradient of 4°C per 1000 ft

#### Instability

7. If the airmass had a temperature gradient of 4°C per 1000ft, as the dotted line indicates, then the parcel of air would never reach the temperature of the surrounding air. Indeed the difference in temperature would become even greater and the parcel would rise more and more vigorously. *The airmass is unstable.* In reality, the situation is complicated by the parcel of air mixing with the surrounding air and consequently cooling at a slightly greater rate than the DALR. Unfortunately for us, on our small island, when we get very unstable airmasses they are often very moist and we run into a whole new set of problems.

### HEATING THE AIR

8. The thermals in which we soar rely upon a constant supply of warm air. Cut off the supply and you cut off the thermal.
9. What is important to remember here is that the degree of instability must be considered in the light of available heating. A very unstable airmass needs only a small amount of heat to create strong thermals, whereas even a stable airmass can produce thermals if enough heat is available to warm the air sufficiently at ground level.

10. Solar Heating. A proportion of the sun's energy is absorbed by the earth's surface, heating it and the air above it, and the more of the sun's heat available the better the chance of good thermals. Different types of surface will transfer different amounts of heat to the air adjacent to them, as some surfaces reflect more of the sun's radiation than others (ie less energy is absorbed). Surfaces inclined toward the sun will heat up much more than surfaces sloping away from the sun. In undulating terrain there can be large differentials in surface temperatures. Although this helps the formation of individual thermals it is still the overall heating that is most important. As a thermal forms and rises away from the ground it will draw in all the warm air from its immediate vicinity. The frequency and size of the thermals depends upon how long it takes for the replacing air to be warmed sufficiently for it to rise.

11. Industrial Heating. As well as being heated by the sun, the air may be heated by industrial or man-made processes. Examples include power stations, steel mills and large fires. However, in order for these relatively small sources to produce decent thermals, there needs to be locally very high temperatures. So, for example, the chimney from a power station will give better lift than the cooling towers. Beware that these processes can be switched off without notice, so although the cooling towers are producing steam, the power station furnace may be switched off.

**THERMAL SHAPE**

12. Given that we have an airmass which will allow thermal development and the sun to provide the heat our next major concern is the development of the thermal itself.

13. The warm air could rise as many very small parcels, which would be of little use to us. We need the warm air to rise in larger more usable quantities and the process which encourages this is very important to us.

Triggering

14. Fig 2 shows the classic beginning of the thermal with its inverted cone appearance as the warm air rises away from the ground. The spot at which this occurs is usually warmer than the surrounding area and we refer to it as a trigger source. Trigger sources are very important to us as when we are low it is through recognising likely trigger sources that we stand a greater chance of finding a thermal.

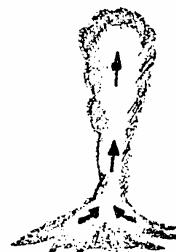

**FIGURE 2**

The beginning of the thermal as a parcel of warm air rises from the ground.

Vortex Ring

15. Figs 3 and 4 show the next stages of development with the column of rising air spreading laterally. As the top of the thermal spreads, the warm air below will continue to push up the centre of the thermal, and it will take on the characteristics of a vortex ring. The depth of the thermal will depend on the amount of warm air available in the locality of the trigger source. If there is only a small quantity of warm air available the thermal will soon break away from the ground and rise as a bubble, maintaining the vortex flow within the bubble.



**FIGURE 3**

Thermal rising and developing vortex ring characteristics.

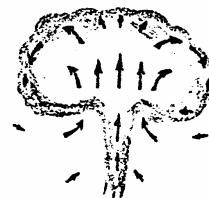

**FIGURE 4**

Vortex flow in an established isolated thermal with the outer edge descending relative only to the core

The Core

16. It is obvious from this that a glider will climb faster in the centre or lower parts of the bubble than it would if it were sitting on the top of the bubble, provided that the pilot maintains his position in the centre or core of the thermal.

**EFFECT OF WIND**

17. So far we have only considered the formation of the thermal in its simplest form with no wind to complicate the issue. As there is nearly always some wind, we need to understand the effect it has on the development of the thermals.

Wind Strength

18. Light to moderate winds are positively beneficial; without them the thermals may not become well formed. Strong winds however tend to break the thermals up and make soaring more difficult, particularly near the ground. The best way to imagine the thermal is as a vacuum cleaner which will suck in any warm air that lies in its path. Once it has left the ground it will draw warm air from the surrounding area and as long as there is a warm air supply it will continue to grow. Now consider the thermal travelling over the ground at 10 knots; provided that the sun has been shining on the ground ahead and the surface layer of air is warm the thermal will continue to develop as it draws in all the warm air in its path.

19. The thermal will maintain its development until it arrives over ground that has no fresh warm air, where the bottom of the thermal will break away from the ground. As the thermal travels along it cannot leave a vacuum behind it and the warm air it has drawn in is replaced by cooler air from above. As the thermal may draw its warm air from some distance either side of its path, it creates an area in which new thermal activity is inhibited for some time after its passing; this effect encourages streeting.

20. As seen in Fig 5, thermals will tend to follow the line set up by a previous thermal. If it were not for the suppression of thermals in these areas we would not get the large well formed thermals we experience on the good days. The suppressed areas allow the few good thermals to draw in most of the warm air available without having to compete with many smaller thermals, the best days being when the system works perfectly with well formed thermals and reasonable streeting. The factors that may disrupt this well-ordered situation are discussed later. It is essential to any aspiring cross-country pilot to recognise the situation changing as early as possible.

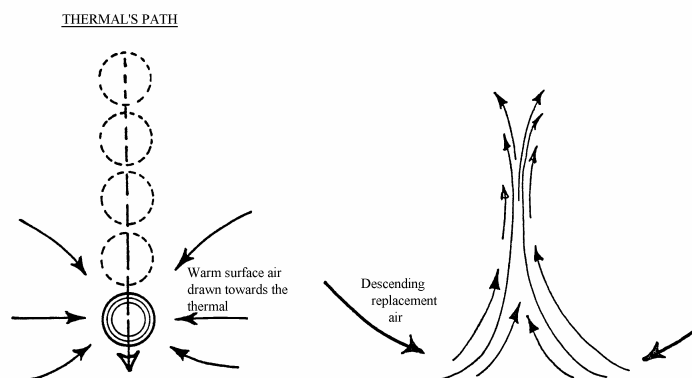

**FIGURE 5**

Any thermal activity in the shaded area is unlikely for some time after the thermal's passing.

## CYCLING

21. You may have heard the term "in phase with the weather" or heard another pilot saying, "I arrived at the cloud too late". The cycling of the general situation we shall deal with later but for the moment we shall deal with the cycling or life of the individual thermal. As you have already seen the thermal usually begins life at a trigger source. These are areas which absorb more of the sun's radiation and transfer it back to the air above them. Lighter surfaces reflect more of the sun's radiation, therefore there is less heat available to warm the surrounding air; likewise in a wet area, where the sun's heat is consumed in evaporating the moisture. If the soil itself has a high moisture content a large proportion of the incoming heat is wasted by absorption within the soil itself. Areas of dense foliage or woods prevent the radiation from reaching the ground and will use much of this interrupted energy in the process of transpiration (evaporation from the leaf surfaces). A large tree may transpire 3 tonnes of water in one day. Woods may retain the heat of the day and become useful thermal sources later, usually after 1600 hrs when they become warmer than the surrounding air and release their stored heat as thermals.

### Factors

22. The width, depth and lifespan of the thermal depends upon a number of factors which are interrelated.

- a. The instability of the airmass.
- b. The amount of heat available (time of day and season).
- c. The surface over which the thermal is travelling.
- d. The wind strength.

23. It is a combination of these factors that will determine how quickly air replacing that used by a thermal can be warmed. If the warming of the replacement air is too slow the thermal will quickly exhaust the warm air supply in its vicinity, resulting in a short life and a shallow bubble which may also be rather narrow. Assuming that the warming of the air is adequate let us consider the development of the thermal as it travels with the airmass. It is unlikely that you will find any terrain which would give totally uniform heating; there will be changes in surface colouring, moisture content or slope almost everywhere. This in turn will result in the air above the ground being of differing temperatures. As the thermal is travelling it may draw in very warm air one moment resulting in strong lift, but as it passes over an area of cooler air the lift will become weaker until it reaches the next patch of warmer air. It is this fluctuation within the thermal itself that can make predicting the next thermal's strength very difficult. Fig. 6 illustrates this process:

### THERMAL'S PATH

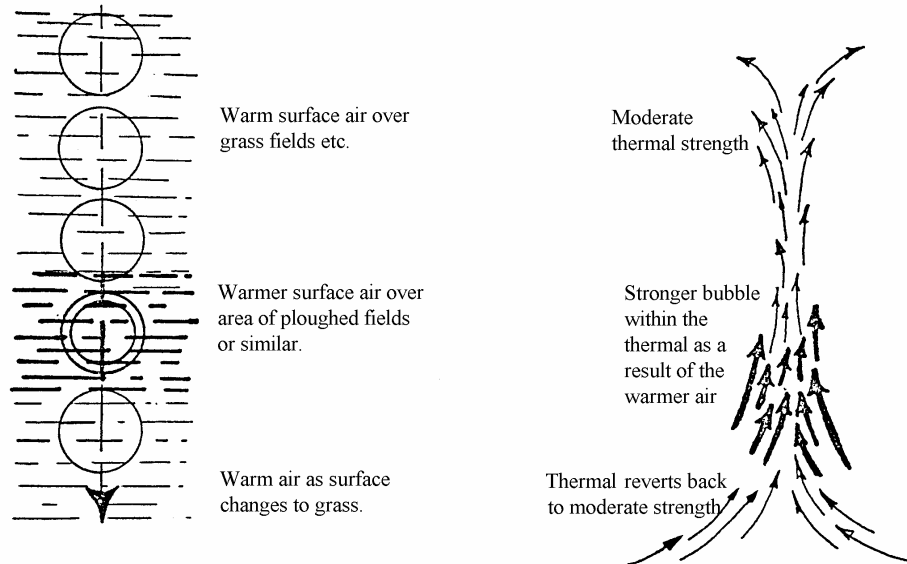

24. A thermal of 4 knots means air rising at approximately 600 ft/min. The air in the thermal at 3000 ft will have taken 5 mins to rise from the ground, in a 12 knot wind the thermal will have travelled over 2000 metres in that time.

25. All that we have considered so far has assumed that the sun is shining on the ground all the time, and the differentials in air temperatures have been caused by differences in terrain or surface. There is however a factor which complicates the issue considerably and can override most of the factors that we have dealt with so far. It is the formation of cumulus clouds on the top of the thermal that can disrupt the process completely. You will almost certainly have noticed the dramatic change in temperature when a cloud passes overhead cutting off the sun. Imagine what a difference it makes to the production of warm air. The relationship between thermals and their clouds is a complicated one and is dealt with in a later section on the subject of "finding your thermal".

## FINDING YOUR THERMAL

1. Before discussing the relationship between the cloud, the thermal and the source of the thermal, it must be said that there are enough variables to make any hard and fast rules impossible. I shall try to create a picture of thermal development that will help you to visualise where the lift ought to be, where I have given specific example it is based on the situation outlined and may not apply in differing circumstances. You should approach the challenge of soaring cross-country with a totally open mind as the best lift you find may be totally unrelated to any obvious source or cloud; don't question it; climb in it. As a general rule if you contact reasonable lift in the blue on a day when there are clouds, use it as it will most likely be a developing thermal and the cloud will form as you are climbing.

### TERRAIN EFFECTS

2. The terrain over which you are flying will affect the way in which the thermals develop, particularly if there is any wind. In hilly or steeply undulating terrain the thermals are likely to stick to their trigger source at ground level, whereas in flatter terrain the base of the thermal will usually travel with the airmass resulting in a near vertical column of air. As you can imagine, the strength of the wind is critical, particularly in hilly terrain.

#### Fixed Source in Light Wind

3. In Fig 1C you can see how the warmer surface layer travels along the ground to a crest or trigger point, here it breaks away and forms a thermal. Although in lighter winds these thermals may be of a fixed source and appear stationary, even these thermals must eventually break away.

#### Pulsing in Stronger Wind

4. In a stronger wind we are more likely to see a broken development as in Fig 2C. Here the thermals break away from the source, resulting in a steady line of short thermal bubbles aligned generally with the wind. The situation may be confused further by a wind-shear and the possibility of wave lift interfering with the development of the thermals.

**FIGURE 1C**

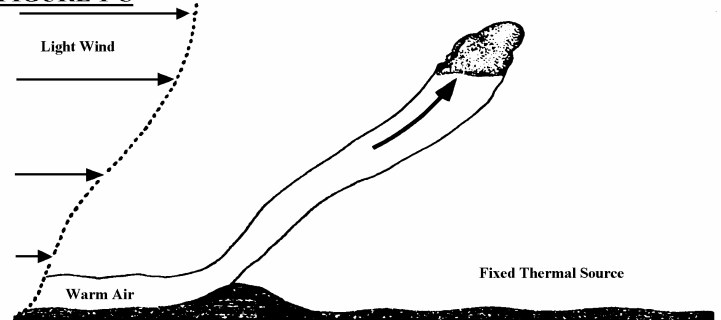

**FIGURE 2C**

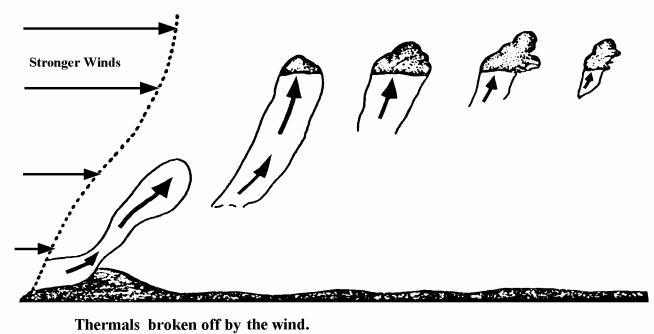

5. Bearing these factors in mind; when flying over or immediately downwind of hilly or mountainous terrain, proceed cautiously particularly if there is a moderate to strong wind blowing. When deciding what constitutes hilly terrain you must take into account the depth of convection. If thermals are only going to 2000' ASL then the Chilterns and Cotswolds would have a very marked effect, if however the depth of convection were 5-6000 ft. ASL one would expect only parts of Wales and the Pennines would seriously disrupt the thermals. Furthermore, when flying downwind of high ground beware of the sinking air over the lee of the hill, and also the potential for wave/rotor to suppress the thermals

### WIND SHEAR

6. The term 'wind shear' means a change of wind speed or direction at a particular height. In gliding, we usually call a change of wind speed near the ground a 'wind gradient', and a change in wind speed/direction at a certain level within the operating band a 'wind shear'.

#### Wind Gradient near the Ground

7. The wind strength will determine the depth of the wind gradient, with the stronger winds creating a more marked change in wind speed within 100 metres or so of the ground. This change in wind speed is obviously going to distort the bubble as it rises from the ground and in all but the most unstable of conditions may break off the bubble too soon, resulting in the thermals being small and narrow. If the air is very unstable these small thermals may still be very strong, although a long climb in good lift is unlikely. Soaring on windy days difficult for a number of reasons: small thermals are usually difficult to centre in quickly, if at all; as the bubbles have very little depth to them it is easy to miss the bubble completely; and relating a thermal to its cloud becomes even more difficult than normal.

8. Fig 2C shows the bending of the thermals near the ground and the effect of the bubbles being broken off, notice, however that they are still likely to form a line downwind of the source.

#### Wind Shear at Altitude

9. Any change of wind direction with height will distort the thermal, possibly shifting the core to one side, resulting in the need to re-center. If you are constantly having to recentre at a particular height this is almost certainly due to a change in wind direction at that height; this will demand recentring by shifting the circle in the same direction at that height. Successful recentring at the shear level can be very important, since it usually allows a higher operating band and consequently higher cruise speeds. Near the surface the wind direction may be as much as 30° different to the wind at flying altitude. This differential reduces as the thermals mix the air in the lower levels but there will remain some difference in direction throughout the day. As a result, one must imagine the thermal having a slight sideways lean as well as a downwind lean. If you look at 'dust devils' or 'twisters' you will notice that as they ascend they literally bend cross wind and there is no reason to suppose that thermals do not bend in the same way. On days when there is an inversion, even weak, any wind shear tends to be at the inversion level. When this occurs it can encourage thermal streets to form, establishing a pattern that bears little or no relationship to thermal sources. It is also a situation in which it may be possible to wave soar up the edge of the cumulus, as the thermals are acting as a resistance to the upper winds like a ridge, creating a wave system above them.

#### LIFT ALIGNMENT

10. On the best 'Streeting' days we see the beautiful parallel lines of cumulus joined together like railway lines in the sky. It is unfortunate that this is not always the case, though it is true to say that there is nearly always some streeting effect even though sometimes it is much less obvious. A comparison of speeds through the air on crosswind legs, against the speeds on into and downwind legs usually shows the crosswind legs to be slower, even when you did not notice any streeting effect on the other two legs. There are three reasons for this, when flying on a track within 30 degrees of the wind direction. Firstly you do not seem to have to deviate too much off track to choose a route under regular clouds. Secondly, you lose less height between thermals by hitting small areas of lift and not experiencing large areas of heavy sink. Thirdly, the lift under a cloud is generally easier to find as you are more likely to fly through the core of the thermal and so centre more quickly.

11. These factors are all as a result of the alignment of thermals even though it may not be at all obvious. In thermal development, the air alongside the thermal is descending, and being warmed as it travels over the ground towards the thermal. This alone may not cause good streets but will discourage thermals alongside the track of any existing thermal, subsequent thermals therefore tend to follow the previous thermal's track.

#### Requirements for Streeting

The best streeting conditions require a combination of factors:

- a. A moderate wind with the maximum wind speed within the convective layer.
- b. A limit to convection depth provided by an inversion or stabilising layer.
- c. Relatively flat terrain bearing in mind the depth of convection.
- d. A wind shear at or near the inversion layer.
- e. The sun being in a position such as not to cut off the street itself.

The first 4 factors are all touched on elsewhere; the sun's effect however has not been explained.

#### Importance of Sun's Position

12. With the sun at right angles to the streets the shadows fall between the streets discouraging the formation of thermals to compete with the street. In Fig 3C you will notice the sun is at right angles to the street, the cloud shadow is cast to one side thus perpetuating the streets themselves, as it is unlikely that thermals will form under the cloud shadow, all the available heating will provide more warm air for the thermals already under the street.

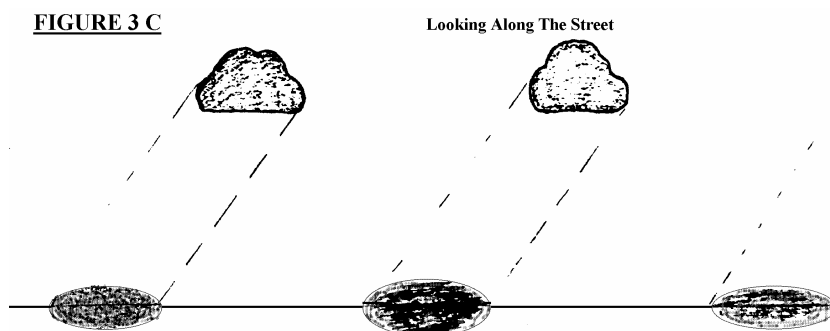

13. With the sun and wind in line the clouds cast their shadows below discouraging good streeting. In Fig 4C you will see that the position of the sun is such that the cloud casts its shadow directly beneath the clouds, in this situation the streets will probably break up, indeed it is unlikely any reasonable street lengths will be formed in the first place.

14. The shadow from the cloud falling almost directly below may cause the thermal to bend and move cross wind. In Fig 5C the cloud's shadow is cast slightly to one side of the cloud, the streets may well continue by drawing the warm air from one side of the street. In this situation you may find that the lift below cloudbase is only good when running down one side, if you are low you may have to fly some way out from the clouds to find the good lift.

15. The effects of lift alignment or thermal trains can be very marked even when streeting is not obvious. One may find when flying 'crosswind' that it pays to arrive at clouds at the downwind edge, then turn and fly into wind under the cloud and leave at the upwind edge, in some circumstances this may reduce the amount of sink you experience when leaving the thermal.

### HEIGHT BANDS AND FLYING TECHNIQUE

16. The most important ability when flying cross-country is that of finding and using lift, all I have said so far may help you to visualise what it is you are looking for and possibly where it ought to be. There are a few pointers to finding the lift quickly and recognising which part of the thermal you are in.

17. The important thing to remember here is that the cloud is a secondary characteristic of the thermal, there can be thermals that have not made clouds and clouds that have lost their thermals. The presence of a cloud does not guarantee a thermal, neither does the lack of a cloud guarantee that there are no thermals. If we consider the space between the ground and the cloud and divide this into three we can deal with each section separately as different techniques apply.

#### Top Height Band

18. When at the higher altitudes in the top third of the dry thermal layer, the thermals are larger and more easily associated with their clouds, this is the band to stay in, unless you do not find any good thermals within it. At this level one looks at the side of the clouds and cannot easily see the bases of the clouds down track, the best lift generally lies beneath the dome of the cloud. From the side one should look for the sharpest edges to the base, this usually indicates clouds that are still working, once the thermal dies the edges will begin to fray and become fluffy. If very close to cloud base you may notice the contour at the bottom of the cloud, if the base is concave this is normally a very good sign, as are wisps of cloud hanging out of the bottom of a good base, both these phenomena indicate higher temperatures and where the air should be rising fastest.

19. If you are not sure how far it is to the next cloud or what conditions are like ahead you can use the cloud shadows on the ground. First work out which shadow is the one belonging to the cloud you are under, then looking down track you should get some idea what conditions are like from the amount of shadows and their pattern. It will often be easier to recognise streeting from cloud shadows than by the clouds themselves and it is useful to compare cloud shadows with your track as this may help you pick the most economical route. There is a tendency to fly too fast when in this top third of the thermal layer especially if you have just had a good climb; with a reasonable cloud base and a good performance glider it is important to remember that you cannot see the clouds where you will need your next thermal. If in any doubt it is better to fly a little more conservatively here and speed up later if you can see good lift ahead.

#### Middle Height Band

20. In this band you should still use the clouds as your main indication of areas of lift, the difference is that you are now looking up at the bottom of the clouds rather than from the side. Crisp outlines are still very important with regular shaped clouds usually being the best thermals. If another thermal has started to feed a cloud the best lift may not be under the dome or tallest part of the cloud; the cloud will have an extension to one side of the dome which when viewed from below may well appear darker and more solid.

**FIGURE 4 C** Looking into or downwind and into or downsun.

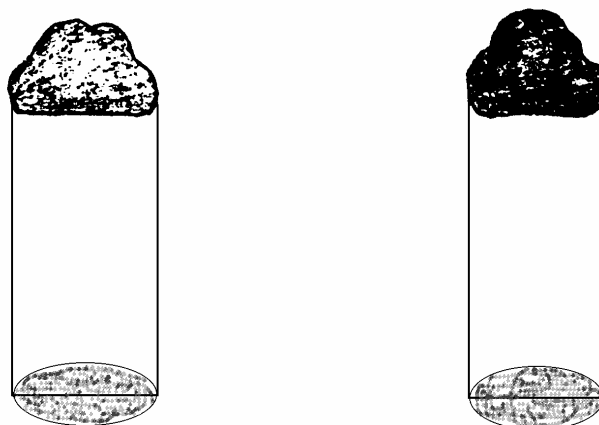

**FIGURE 5 C** Looking Downwind

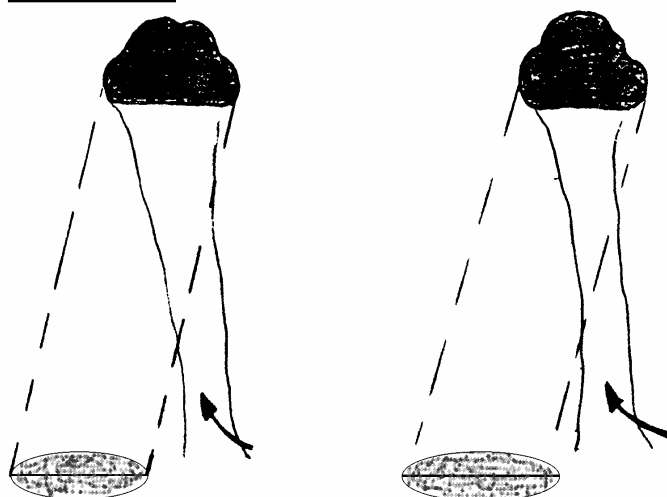

21. A cloud in this stage of development when approached from the side may indicate the best lift toward the downwind end of the cloud, but on arriving below the cloud it may pay to fly into wind under the darker more solid looking part of the base. The only way you can be sure that a cloud is still working is by going there, but by observing the cloud whilst approaching it you should see if the cloud is growing or declining.

22. On a reasonable soaring day over flat terrain you can generally expect the thermal to be more or less directly below the cloud, if flying over hilly terrain you may have to decide whether it is a fixed source thermal or a moving thermal. If you are not sure and arrive under the cloud and find no lift, turn into wind and fly for a moment or two. If it is a fixed source, then you may well hit the thermal upwind of the cloud. Do not ignore cloud shadows as these may influence the position of the thermal relative to the cloud (see next paragraph).

#### Lower Height Band

23. It is in this height band that finding a thermal can become most difficult and unfortunately it is most essential that you do so, by a mixture of cloud and ground reading. In light winds on good days it is still possible to use clouds almost exclusively, if however it is a day with short thermal bubbles, although the cloud itself is unlikely to work down to this level, it still may be used as a guide. Don't ignore clouds when low, they are usually the best indication of lift even from quite low altitudes, it is normally a big mistake to fly away from clouds into the blue unless you have some very good reason (such as a stubble fire).

24. Remember that lift usually follows roughly the same line so when low you must try to use the cloud and imagine where the next thermal would come from, if you cannot see any obvious sources and the cloud looks like it is working at altitude fly from under the cloud into wind, if there is another bubble forming or already formed there is a good chance of hitting it. If it is the bottom of the thermal it is generally a little turbulent with no real 'life' in the air, you will learn to recognise the feeling of not climbing although the vario may keep indicating weak lift. It is normally best to leave this lift particularly if you have sufficient altitude to search, if no other option suggests itself fly into wind.

25. If the lift is weak but smooth and you are actually climbing, albeit quite slowly this may be the top of another bubble starting to rise, hang on and see if the lift improves. In both cases look downwind, which is the direction the thermal is travelling, and see if the sun is shining on the ground you are about to drift over. If it is in shadow you may be unlucky as the thermal may die through being starved of warm air. If however you are drifting towards a sunny patch, or a valley which has just had the sun in it, you may be lucky as the thermal becomes strong by collecting this warm air.

26. Cloud shadows play a big part in thermal location low down, they may cause a thermal to bend in a most unlikely fashion, for example a thermal may draw its warm air from one side of a cloud shadow and flying directly under this cloud may lead you to believe the thermal has finished. This effect is normally most prevalent when short streets occur casting their shadows almost directly below, when faced with this situation it is usually worth a look to one side.

## USING THERMALS

1. This lesson is concerned with centring quickly, and maintaining the circle in the best possible lift, since in order to increase his cross country speed the sailplane pilot must:

- a. Find his thermal more quickly.
- b. Climb in it as quickly as possible.
- c. Know when to leave it.

### THERMAL STRUCTURE

2. Practical experience, in general, suggests that a typical thermal is roughly circular in cross-section; has a strong core of lift, tapering to weak lift near the edges; and is surrounded by air which is sinking. The thermal may be 'mapped' with "contours" of sink and lift (**Fig.1**). Depending on the source of lift and the height above the ground the thermal may be a stream of rising warm air, like the smoke from a stubble fire in autumn, or it may have become detached from its original source and be an isolated bubble with a distinct vertical circulation (**Fig 2**). In either case the pilot's objective is the same - to locate and circle tightly round the core of rising air.

### AIDS TO LOCATING THE CORE

3. The pilot can't usually see the core. There may be clues in the patterns of the cloud bases (and brown or yellow tinted sun glasses are best for seeing these) or the thermal may be marked by smoke, or soaring birds or gliders. But usually the pilot has to rely on his variometer readings, or on his physical sensations as the glider enters the thermal. The snag with the variometer methods (often known as "best heading" or "worst heading") is that the pilot can only begin to deduce the pattern of lift and sink after the glider has been in the thermal for at least 15 seconds i.e. when he has completed most of his first turn. And then he must allow for a 3-4 second lag in the vario reading - after all, the simple vario is measuring air flowing in or out of the flask, and no air can flow until there is a difference in pressure between inside and outside - that is until the glider has actually risen or descended several tens of feet. After the inevitable delay; then, the pilot can begin to work out which heading shows best or worst lift and can then make appropriate corrections. Multiply this delayed reaction - say half to one minute - by the number of thermals needed, plus the probably larger number of thermals rejected after sampling, and the pilot relying on variometer indications will fall further and further behind. He needs to speed up his analysis, to work out the air movement patterns directly on the physical sensations available - seat of the pants stuff!

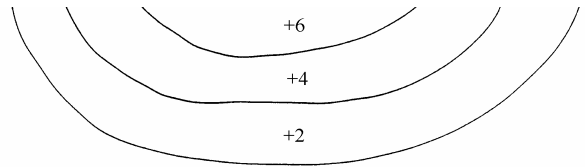

FIG 1 'CONTOURS' SHOW REGIONS OF SINK & LIFT.

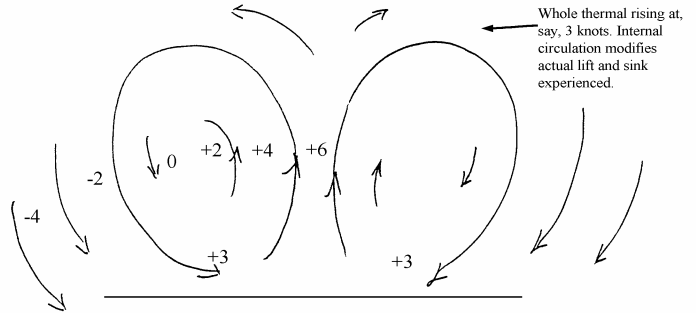

FIG 2. VERTICAL CIRCULATION IN A TYPICAL THERMAL.

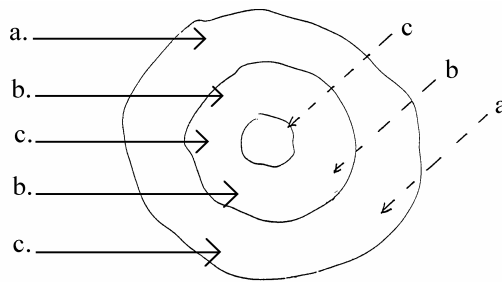

FIG 3. THREE WAYS INTO A THERMAL.

- a. the edge
- b. half way
- c. the core

	SENSATION		REACTION
	LIFT	TILT	
a.	Slight (actually reducing)	Mod to left	Prepare for right turn
b.	Nil	Max to left	Slow down, turn right
c.	Increasing	Max to left*	Maintain right turn
d.	Nil	Max to left*	Tighten right turn
(Tendency to tilt 'masked' by being banked)			

FIG 4. ENTERING ONE EDGE.

The **amount** of turn must depend upon the pilot's judgement of how big the thermal is, and that will usually depend upon how high he is. Thermals expand adiabatically as they rise so that a thermal at 3,000 ft. will be distinctly larger than it was at 2,000 ft. The greater the height at which the thermal is contacted the further the glider will need to track sideways to find the core, and the wider will be the sweep round towards the rising wing.

**ENTERING THE THERMAL**

**Lifting and Tilting**

4. On entering the thermal the pilot may notice two basic physical sensations - being **lifted** (positive 'g') and being **tilted** to one side. The degree of each are his clues to the location of the core and will determine his reaction. The glider can fly into the area of the thermal on one of only three basic tracks (**Fig. 3**):

- a. Well towards the edge.
- b. Halfway between the edge and the centre.
- c. Head on towards the central core.

The degree of lift or tilt will depend on the relationship between the glider's track and the lift/sink "contours" of the thermal.

**Edge of Thermal – Minimal Lift, Maximum Tilt**

5. Flying through the edge of the thermal (Fig. 4) the glider will be flying along a set of "contours", and there will therefore be **minimal lift** sensation. Bear in mind that the sensation of being lifted is an **acceleration** upwards (or, confusingly, it may be a slackening of downward acceleration!) and in order to **feel** such lift it would be necessary to be flying into air which was rising more quickly than that which has just been left behind. At the same time, the wings are disposed at right angles to the lift contours and therefore there would be **maximum tilt**.

**Midway Between Edge and Core – Moderate Lift and Tilt**

6. If the thermal is contacted mid-way between edge and core (**Fig. 5**) the physical sensations will have changed to **moderate lift** - rather more contours being traversed in the flight direction - and **moderate tilt** - the wings are no longer directly across the contours. The response should be a sharper turn in the direction of the rising wing.

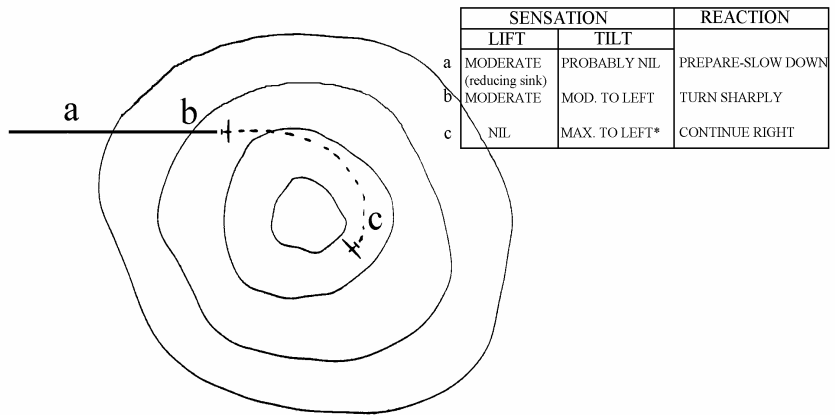

**FIG 5. ENTERING MIDWAY BETWEEN EDGE AND CORE**

**Head-on to Core – Max Lift, Min Tilt**

7. Finally the glider may be flying head on to the core (**Fig 6**). Now the sensations will be **maximum lift** and **minimal tilt**. Depending on the speed of the glider and the size of the thermal the sensation of lift may be quite dramatic and the temptation is to charge straight on hoping for more of the same! In fact to arrive directly in the centre of the core may be a mistake, because a turn either way is bound to carry the glider away from the centre. The reacton should be to turn a little either way and then turn back sharply in the opposite direction when the wing is felt to tilt in response to being placed across the contours.

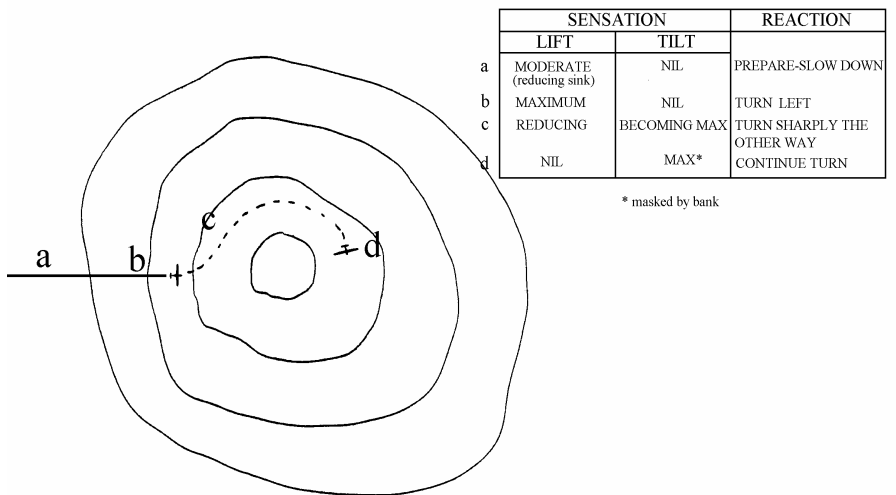

**FIG 6. ENTERING HEAD-ON TO CORE**

**PULLING UP**

8. In all three cases the glider is usually being flown fairly fast having just come through the surrounding sink and in addition to sorting out his impressions of lift and tilt the pilot must also react quickly in order to slow down. The resultant pull up may well mask the more subtle sensations derived from crossing the thermal contours so the pull up should be smooth and progressive rather than abrupt and rough.

The degree of pull up will depend on which entry path has been flown. The most urgent is the head-on case. The speed must be reduced quickly if the glider is not to shoot straight out of the far side of the thermal especially at lower altitudes. The ensuing twisting turn could amount almost to a chandelle in extreme cases.

## STAYING IN THE CORE

9. Having located the core approximately it is important to centre on it and to stay centred. The technique now amounts to reacting correctly to each gust encountered especially the vertical gusts. The idealised "doughnut" thermal of Fig 2 is rarely as smooth as the picture suggests. The core of the thermal is often rough and bubbly and the best soaring pilots will always succeed in outclimbing their fellows even though all are apparently flying exactly concentric circles of about the same radius. In fact the better pilot will be varying his circle slightly to take advantage of each gust. In a very crowded thermal it may not be possible to make the necessary adjustments safely and at this point the best pilots will often leave to find a more solitary thermal where they can exercise their special skills.

10. This skill involves slackening and tightening the turn often by only very small amounts - say a few yards shift in the course of the quarter turn - and it rarely amounts to what the novice would consider to be a re-centring manoeuvre. As he senses the lift beginning to increase - upwards **acceleration** (Fig. 7) - he widens the turn, perhaps by reducing his angle of bank by 10 or 15°. As the lift peaks - upwards **acceleration** ceases - he quickly tightens the turn again. After all, if he is in the best lift, then by definition, since he can't stop the aircraft in mid air, he must be about to leave it again. So he tightens the turn to stay as close into the core as possible. Timing of the small adjustments is all important. Fig 8 shows what would happen if all the responses were delayed by about 3 seconds. The centre of successive turns would shift round and round the perimeter of the core and the glider would never get centred. As well as that of the pilot the response time of the glider may be significant. A fully ballasted aircraft cannot roll very quickly, and on a day of rough "difficult" thermals it may be better to dump water and sacrifice enhanced speed in the glide in order to improve centring and climbing ability. Also in order to make smooth and properly co-ordinated corrections a glider must not be flown too slowly. The temptation to fly at less than minimum sink speed in order to reduce the radius of the turn should be resisted until the pilot is satisfied he is really centred. And the best pilot is rarely satisfied!

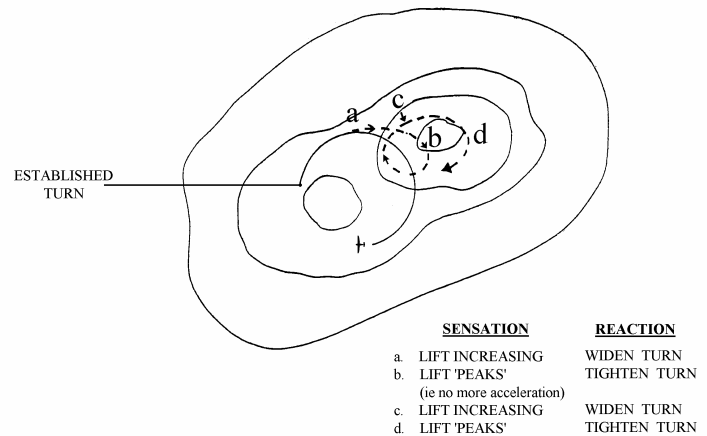

FIG 7. - RECENTRING

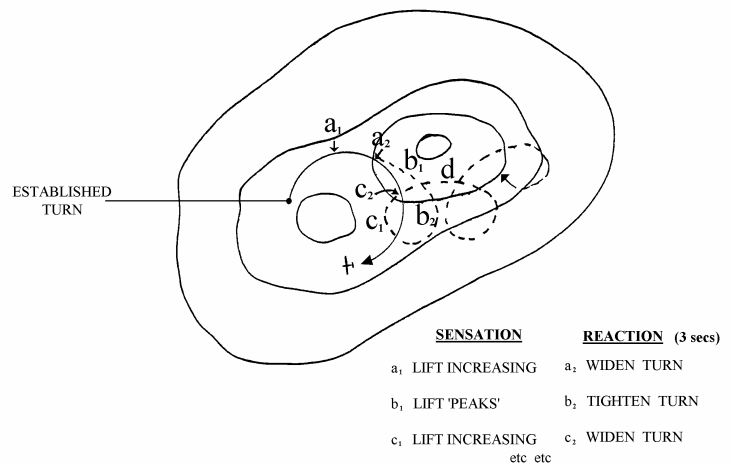

FIG 8 - RECENTRING TOO LATE

## ANGLE OF BANK

11. Finally the best angle of bank needs to be considered. The requirement is to climb as quickly as possible and this means tucking well into the core of the thermal. Normally the best angle of bank will be 30-45° but exceptionally up to 60° may prove necessary. As the bank is increased of course so does the load the wings have to carry. At 60° this load is exactly twice normal 2G. The stall speed also goes up (x1.4 @ 60° bank) as does the rate of sink. So a tightly banked turn means a relatively high rate of sink, and this will tend to cancel out the advantage of being closer to the centre of the core. For each thermal there will be an optimum angle of bank, and on a given day and in a given height band this angle of bank will probably not change. But exceptionally, say in a stubble fire at about 1000 ft. or getting away from a hill low down, the best angle of bank will be very different. In the cases quoted a much steeper angle will be needed because the thermal is much narrower. As the glider climbs and the thermal expands, it would normally be possible to widen the turn, and slow down correspondingly.

## CONCLUSION

12. To sum up then, it is necessary, having decided a likely thermal source, to locate the core of best lift; to stay wrapped around the core if it tends to shift its position; and to adopt the angle of bank which results in the best possible climb in that core. Having mastered these fundamentals the pilot may go on to consider how best to use the height he has won.

# CROSS COUNTRY FLYING - GLIDING

## CRUISING

1. We may consider cruising to be any part of the flight not spent climbing. This is not altogether true as we should spend a considerable proportion of our time climbing in the cruise, eg pull ups, flying slowly through lift, etc. So we will for our purposes, consider cruising to be any time when we are not thermalling. Cross country speed is directly related to three factors:

- a. Cruising speed.
- b. Climb rate.
- c. Route through the air.

2. In soaring conditions that remain fairly consistent the speed to fly is determined by the achieved climb rate, which we must define before we can talk about Macready speeds. The achieved rate of climb is not the same as the rate of climb indicated on the averager once established in the climb, since it must include time spent searching and centring.

3. To establish the achieved rate of climb it is necessary to time your climb from the moment you start to turn, to the moment you roll out of the last turn. Although with practice it is possible to assess the achieved rate of climb from the vario and type of thermal etc, an averager is invaluable. If no averager is fitted, you should use a stop watch from time to time to check how accurate your assessments are. If you are achieving a 4kt climb and can reasonably expect to continue doing so, then set the Macready to 4kts. Now fly at the speed indicated by the vario.

4. Sounds easy doesn't it? It would be if it were not for a number of other factors such as; changing conditions, distance between thermals and having to stop to take the odd 2kt climb. In soaring conditions that do not look consistent then the speed to fly is not easily determined and may change every few moments, or after every thermal.

5. The climb rate depends on the thermal strength coupled with the pilot's ability to centre and climb efficiently. Although we can do nothing about the thermal strength, we can boost our overall rate of climb by only using the stronger thermals available to us. If one calculates the total height required in a particular distance say 6000ft to cover 50km. With an achieved rate of climb of 4kts in each thermal we would spend approximately 15mins climbing. If however, half our thermals only gave us a 2kt climb, we would spend 22½mins climbing, a third longer, plus a correspondingly lower cruising speed.

6. The route through the air can only be determined by the pilot's interpretation of the sky. It is not the intention to cover any techniques relating to sky reading in this paper, only to add the comment. "It is better to be flying in still air or air rising at ½ knot than to fly through sinking air".

## OPERATING BANDS

7. It is necessary, then, to adopt a technique when flying cross country that will enable you to practise the techniques of selecting and rejecting thermals. The technique that we look at here should enable you to do this, and still fly with a reasonably good chance of avoiding too many out landings. The technique is based on establishing operating height bands, and following certain rules whilst flying within these bands. The depth of each band and its upper and lower limit must vary with pilot experience and glider performance.

8. When embarking on your cross country first establish the cloudbase, and the average thermal strength. This can be done whilst local soaring prior to setting off or during the first few kilometres of the flight. Assess the conditions down track using cloud shadows if high and the clouds themselves if possible. If the conditions look at least as good as you would expect for the cloudbase, and the thermals are well spaced, then you can establish your operating bands.

9. **EXAMPLE:** Cloud base 4000 to 4200ft. Thermals 4 kts occasionally 5kts: operating height band, cloud base down to 2500ft. Minimum thermal strength required to stop and climb 4kts. Select an appropriate Macready setting.

10. Now having climbed in a 4 kt thermal to cloudbase, set off along track, weaving under any likely looking clouds. Only stop to climb if you encounter lift of 4 kts or better. If you are consistently hitting 4 kt thermals and making small climbs then raise the minimum climb strength to 4½ or maybe 5 kts. Should you reach 2500ft (which you most certainly will sooner or later) you must ask yourself; have you:

- a. Flown straight to this height without a single climb.
- or
- b. Made good progress using several thermals and covered a respectable distance.

If answer 'a' applies:

- (1) Have you set the minimum climb strength too high?
- (2) Have you passed through the edges of the thermals that would have given you 4 knots in the middle.
- (3) Have you just flown across a large blue patch.
- (4) Are you flying along between two cloud streets.

OR maybe you should stop flying round the thermals and try flying through them.

11. Whether situation is 'a' or 'b' you are entering your buffer operating band, which can be anything from 300 to 1000ft thick depending on cloudbase, glider performance, pilot experience, etc. Wind back your Macready ring to half the value used in the operating band and continue to progress, at the new speeds. Should you pass through to the lower limit of the buffer height band without climbing, reset the MacCready at zero for best gliding angle.
12. When you fly into a thermal in the buffer zone, that is between 2 to 4kts, climb only to sufficient height to ensure reaching the next thermal safely. Unless of course your thermal gets stronger and you are able to achieve a 4kt rate of climb.
13. Once below the buffer zone apply the same principle. Avoid climbing all the way back to cloudbase at 2kts, because after leaving it you may well arrive in the next thermal at 3600' to find 6kts.
14. This way you can tiptoe along until you hit a stronger thermal and climb back well into your operating band. If, after three or four thermals you have not encountered a strong thermal, it may be prudent to climb back to cloudbase in a weaker one. You may have flown into changing conditions without recognising it, or the thermals may only be strong at high levels.
15. Having climbed back into your operating band it may be necessary to reset your height bands and your critical thermal strengths and start again.
16. It should be apparent that the thermal strengths and levels set should be interpreted with common sense. For example, using levels as shown in our diagram, it would be rash to reject a 3 kt thermal at 2600ft unless there was a much better looking cloud ahead. Better to take 400ft at 3kts and then sample two more thermals, than be forced to climb 1000 ft at 2 kts.



'Operating' band 2500 ft AGL to cloudbase.  
Climb only in thermals 4 kts or better.

----- 2500 AGL

'Buffer' height band 2500 ft to 1800 ft AGL.  
Climb only in thermals 2 kts or better.

----- 1800 AGL

Below buffer height band.

Stop and climb in any thermal, but not all the way to cloudbase unless more than 4 kts. Set Macready to 0 for best glide angle.

**FIG 1**

17. The whole technique is based on flying through all the available thermals along your route, and the conditions not changing significantly. It is easy to be flying along successfully, blunder into an area of poorer conditions and fail to slow down in good time, thereby getting too low before recognising it. *Always look well* ahead and modify your height bands and MacCready settings as appropriate. If in doubt, slow down.

18. When you have developed some skill at determining the correct thermal strength, then experiment with the height bands. By lowering the buffer 500' top and bottom you may increase your speed slightly but you will also increase the risk of landing out.

19. Lowering the levels to which you are prepared to descend before slowing down is largely a matter of confidence. Below 2000ft is generally accepted as being nearer low than high and certainly 1000ft is low.

20. If you are often descending to 1000 ft before slowing to best glide, you are either flying in the Nationals (probably badly) or being grossly over confident.

### **SUMMARY**

21. The correct speed to fly between thermals depends primarily on the rates of climb achieved. Decisions to vary the parameters used have to be made by the pilot in view of circumstances which become evident during the flight. Quite often slower air speeds than are theoretically correct give a better average speed because fewer thermals need to be used, and the operating band is higher.

## SPEED TO FLY

1. Having learnt to climb as quickly as he can in each thermal, the pilot has to use the height he has won as efficiently as possible. He must not waste it in a glorious burn-up, nor drift slowly along when he should be making better time. He has to learn to fly at the right speed.

### BASIC SPEED TO FLY THEORY

2. The basic theory on speed to fly is generally credited to Macready, from about 1952. In fact the bones of the modern theory were formed some years earlier.

3. In essence the glider should be flown between thermals at an average speed which depends on the rate of climb achieved in the thermals. Reasonably efficient progress may be made if the average rate of climb is measured for each thermal, and a steady speed flown according to that rate of climb. This speed may be derived by examining the polar curve of the glider. **SEE FIG 1**

4. The axes of the polar are rate of sink and airspeed. By extending the sink axis upwards (above zero) it may be used to plot the rate of climb. If a tangent is drawn from the average climb rate (4 kts. in this example) to the polar, the point of contact of the tangent indicates the best speed to fly. As the rate of climb increases the tangent makes contact further and further down the polar curve, indicating that a higher speed should be flown. This simple theory is well known and understood but it rarely supplies the whole answer to the speed-to-fly problem.

### WHAT IS THE RATE OF CLIMB?

5. The rate of climb to be used for calculating the speed to fly must be measured over the whole duration of the thermal climb, from the moment the straight glide is interrupted to the moment it is resumed again. A simple and useful guide is to use as an average about half the rate of climb the pilot thought he was getting. Human nature being what it is the pilot only remembers the best bits. For the record, regular thermal climbs in excess of 4 knots in the U.K. are rare, certainly rare enough for a 4 knot setting on the speed ring to be viewed with grave suspicion! It is possible to time climbs with a stopwatch etc. but this method is rarely used by experts who more likely depend on their own judgement of conditions. Finally electronic averagers are now common and any honest pilot is quick to confirm that his private and pessimistic estimates of climb rates achieved have probably not been pessimistic enough!

### WHICH RATE OF CLIMB?

6. Should the rate of climb used to determine the speed to fly be the last one or the next one? A typical cross-country includes a series of climbs and glides and it is tempting to assume that each unit i.e. one climb/one glide will be the same as the last. If it were there would be no problem. But in reality rates of climb will vary with the time of day, the terrain flown over and quite often the amount of cloud cover which has developed. So the pilot must be always watching ahead for signs that the rate of climb he is likely to achieve may be different from what has gone before. He cannot really decide how fast to fly until he has climbed as high as he needs to in the present thermal, and thus the unit he has to consider is in fact one glide/one climb. So, if the expected rate of climb in the next thermal is likely to be weak - perhaps inhibited by a locally over-developed strato-cumulus patch. The glide should be flown relatively slowly, to conserve height, and the preceding climb should be continued until the achieved rate of climb (not the average this time) falls to about the rate to be expected in the next thermal. The ability to accurately anticipate the next rate of climb is one of the special weapons in the armoury of the pundit and is usually the result of many thousands of miles cross-country flying. It cannot be learned from books, or in the classroom. Only in the sky!

7. When the thermal ahead is expected to be much better than the present one, a different problem arises, Now the pilot is eager to get there and will start to speed up. How much he may speed up depends on how late he spotted the bonanza ahead! If he was a bit slow about it, and has plenty of height, he may plan to use all but, say, 1500 ft of his height, and speed up accordingly. But he must bear in mind that the lower he is when he contacts the new thermal the greater the chance of missing it, or having difficulty in centering into the core. If on the other hand he had plenty of warning of the good lift - say a stubble fire, or more likely a power station, or factory complex - he should set up a climb/glide unit rather like a final glide, planning to climb just high enough to glide at the speed relevant to the achieved rate of climb (not the average), and to arrive at the lowest safest height. To do this accurately he needs a flight director, or at least a calculator that can be used for en-route decisions and not only final glides to a single predetermined destination.

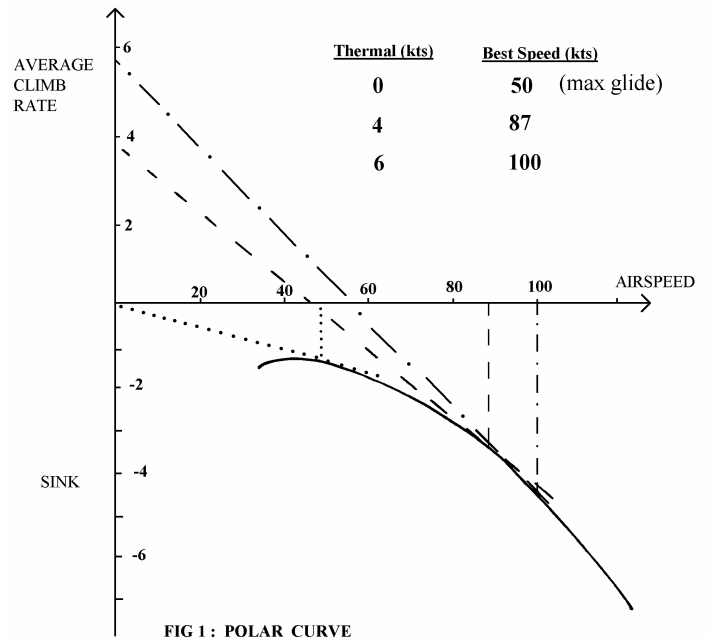

FIG 1: POLAR CURVE

## **SPEED RING SETTING**

8. In all cases, when he has decided what rate of climb is pertinent to the glide to be undertaken, the pilot should set his speed ring (or his flight director) to that rate of climb, and should then follow the vario fluctuations closely. But not blindly! His assessment of lift ahead must be cautiously updated, and the speed ring reset if conditions warrant it.

9. If a conventional vario is used, it is very helpful to speed ring flying technique if a netto system is incorporated. 'Netto' is a new name for an old idea. Again the original idea is credited to Macready, and first appeared around 1955. It re-emerged when glider performance levels rose drastically with Wortmann, Eppler and glass fibre around the late 1960's.

10. The essence of netto is that the vario no longer shows the sink of the glider, so that, increasing speed when sinking air is encountered, the vario does not go even further down the scale, thus demanding more speed, and so on. Without netto there is a tendency to oscillate between going too fast and going too slow, especially since the air mass movements do not stay constant for very long at a time. Netto removes the oscillatory tendency and makes for smoother more accurate speed changes.

## **FOLLOWING THE ENERGY**

11. In certain conditions it is possible by careful choice of route to fly through more than the average number of thermals on the way to the next climb. The more obvious examples are cloud streets, but even when streets are not too evident it is often possible by selecting fortuitous groupings of small cumulus to fly long distances before needing to stop and top up. In these circumstances speed ring flying is again modified in that the conservation of height is paramount. Usually a slower speed ring setting is better, so that the 'energy gap' that which prevents the glider from flying directly from A to B, without height loss, is narrowed. After all a modern glider needs only to fly in air rising at just over one knot to go on forever. By slowing down 5 or 10 knots, less height is lost, and fewer stops (with the time wasting fumbles trying to locate the core) are needed. Days when this becomes possible usually have lowish cloud bases, about 4/8 cumulus, and not much wind.

## **SUMMARY**

12. The correct speed to fly between thermals depends primarily on the rate of climb expected in the next thermal. Decisions to vary the parameters have to be made by the pilot in view of circumstances which become evident during the flight. Quite often slower airspeeds than are theoretically correct give a better average speed because fewer thermals need to be used.

## FIELD LANDINGS

1. If you fly gliders cross country you must be prepared for the occasional field landing. At best, the altimeter will only give an approximate height AGL. The heights shown below therefore are merely for your guidance and you must not rely on the altimeter. Let your eye be the judge of height and perspective, particularly in the latter stages of your circuit.
2. AT 2000'. If a landing appears probable, fly to suitable area, (preferably flat and unobstructed). Remember that you will have a greater range downwind than into the wind. It is advisable to fly a complete turn so as to examine all of the options; for example there may be a suitable airfield within range.
3. BY 1500'. Pick an area with two or three potentially suitable fields. Consider the surrounding terrain:
  - a. Are there hills to create turbulence or surface wind problems?
  - b. Are there power lines, TV masts or other large obstacles?
  - c. Does the ground slope visibly? Any visible downslope whatsoever is unacceptable.
4. BY 1000-1200'. Select your field considering the following:
  - a. Shape and size. You can assess the size by reference to familiar objects such as trees and buildings. A suitable field would be no less than 500 metres long in a direction aligned with the wind, provided that it has an unobstructed boundary on the approach. The field could be relatively narrow as long as it is well aligned with the wind. If the fields are rather small, bear in mind that the longest dimension is usually a diagonal.
  - b. Surface. Use the following order of priority when selecting your field:
    - (1) Stubble. (Depending upon the time of year). Modern farming methods involve the use of the same wheel tracks for each treatment of arable crops. This leaves very obvious 'tramlines' which can become very deep and hardbaked by harvest time. It is advisable to land parallel to and between the tramlines if there are any present. Check carefully too for the odd bale of straw left laying about. Do not be tempted by fields with the bales still in them, as the spacing between the rows is rarely greater than a glider's wingspan.
    - (2) Short crop. The surface should appear more brown than green. You can expect a certain amount of flack from the farmer if you land in his crops, but in the early spring, when the crop is barely through, you will not do much actual harm. If you can see the wind causing ripples in the surface of the field then the crop is too deep to land in safely.
    - (3) Grass. Beware of strip grazing controlled by electric fences. Any striped shading of the grass surface almost certainly indicates the presence of electric fencing which is invisible from the air. Meadow grass may usually be distinguished from young crop by its slightly uneven texture and perhaps the presence of drinking troughs. Deserted pasture land in the late afternoon may mean that the cattle are in the milking parlour and will be back later.
    - (4) Tall Crops. Some crops, such as oil seed rape, become so tall and thickly matted together that it is impossible to walk through them. You should refer to the article by Adrian Hatton in S&G May/Jun 01, and also his website [www.fieldlandings.co.uk](http://www.fieldlandings.co.uk).
  - c. Surface wind. Assess the wind by means of nearby smoke sources, ripples on cornfields or water. Cloud shadows will show the wind at height but the surface wind may be a little backed from this. If there are no obvious indicators of the wind direction, use the wind on takeoff as a guide. Except in the lightest of winds you should always aim to land in a direction that will give you a substantial headwind component.
  - d. Slope. Any downslope in the field is unacceptable. Examine surroundings for slope indications such as rivers. Fields will generally slope down towards a river. Good level ground indicators are bodies of water, railway lines and trunk roads which, for the most part, avoid steep gradients. If slope cannot altogether be avoided, it is preferable to land up the slope in a modest crosswind than to land downhill just to be into the wind.

e. **Obstructions.** Obstructions on the approach cut the usable field length by at least 10 times the height at which you clear them, so a 50 ft obstruction will write off 150 metres of your field's length. Trees and buildings may create turbulence. Electricity supply cables to farms and isolated houses are usually supported on wooden poles. These poles do not show up well from the air, but shadows may betray their presence. Treat any line feature across a field as suspect; it may turn out to be a sunken track, a ditch or a fence of some sort.

f. **Livestock.** Avoid fields with stock in them except as a last resort. Sheep tend to distribute themselves uniformly over a field, leaving no clear landing area. They can run fast and can leap very high if startled. Cattle are inquisitive and will trample a glider, but at least they tend to remain in a herd and leave space for landing. Beware the lone 'cow' in a field as it is probably a bull and may view you as a mortal enemy. Strangely enough a bull accompanying a herd of cows is always placid. Horses can be very excitable, as can their owners, so both are best avoided.

5. **BY 800' AGL** - Having completed the **Pre-landing Checks** (paying particular attention that ballast is dumped and the wheel down) position the glider well upwind and well to one side of your field. Visualise the length of the downwind leg at your home airfield and use pre-selected ground reference points to maintain orientation when positioning. Be conscious of the tendency to cramp a circuit when field landing and avoid doing so. A sensible length of base leg will allow a scope for adjustment that will not be available if the base leg is too short. Landing wheels-up is most inadvisable: the fuselage of a modern glider is thin and will absorb little energy on impact with a rock or other obstruction, resulting in serious injury to the pilot, whereas the wheel and its mounting structure will absorb a great deal of energy.

6. **BASE LEG POSITION** - Plan to be abeam of your touchdown by around 500' AGL. Resist the common tendency to position the base leg too close, thereby causing an overshoot. You will probably need to be 2 or 3 fields back from your chosen one when turning finals. Plan for a half airbrake approach as judged by the perspective. Maintain a safe approach speed as insufficient could cause an undershoot and excessive speed may produce an overshoot. Allow an adequate margin of height over obstructions. Once you are certain you can clear them safely, use full airbrake to achieve an early touchdown. Hold off fully for a minimum touchdown speed as the surface will usually be rougher than at an airfield. Concentrate on keeping the wings level if landing in crop to avoid a ground loop.

7. **ACTIONS FOLLOWING A LANDOUT.** If the landing occurred during a planned cross country flight and was uneventful then the following actions will be required:

- a. Safeguard the aircraft as far as possible from the wind, animals and members of the public. If 2 persons were on board one is to stay and guard the aircraft.
- b. Contact the retrieve crew with exact details of location of the aircraft and how best to reach it.
- c. Inform the landowner or his agent and make a note of his name and address. Explain what is involved to retrieve the aircraft. No liability is to be admitted for any damage but care must be taken to keep crop damage to a minimum during the retrieve. All gates are to be left secure or as found.

8. There is no doubt that more accidents to gliders happen during field landings than in any other phase of flight, including training!. An analysis of accident reports reveals a sad catalogue of likely errors. The following list is by no means exhaustive but it highlights pitfalls to be avoided:

- a. Decision to land made too late.
- b. Misjudged the wind direction.
- c. Field selected was unsatisfactory.
- d. Inadequate assessment of field. Failed to spot obstruction.
- e. Cramped circuit, causing high and fast approach. Groundloop to avoid hedge.
- f. Last minute Change of mind. Alternative worse than original!
- g. Attempting to soar away from too low an altitude.

## PROCEDURE AFTER A COMPETITION LANDOUT

### 1. PRE-PREPARATION

- a. Have with you a suitable bag into which you can put all of the Valuable and Attractive items such as cameras, barograph, GPS and the like, when you leave the aircraft unattended.
- b. Most contest organisers have the Control telephone numbers printed on their task sheets but it pays to write them on the margin of your 1/2million map, so that you know that they are with you in the cockpit.

### 2. AFTER LANDING

- a. Even if you have notified you crew by radio of your landout intentions, you must phone. Competition Control expects a phone call from you afterwards to confirm that you are safe and to process your details for provisional scoring. Make sure that you have precise details of how the crew can reach you worked out before you make the call.
- b. Try to prevent further crop damage by keeping sightseers away if possible.
- c. Contact the landowner or his agent (Over the phone if necessary) and remember that you are an uninvited guest:
  - (1). Tell him what you have done.
  - (2). Seek his guidance on how to retrieve the glider.
  - (3). Be suitably apologetic and contrite.
  - (4). Note his name and address for your follow-up with a 'thank-you' letter.
  - (5). Close all gates after you, bar those found open.
- d. If you want an aerotow retrieve, ensure that:
  - (1). You have the farmer's permission.
  - (2). The field is large enough, and the surface is suitable.
  - (3). There are no potentially hazardous obstructions for the tug's approach or on the proposed climb out path.

NOTE: If you call the tug out on a wild goose chase you will end up paying twice for the retrieve.

- e. Get your landing certificate signed by 2 witnesses (or 1 Official Observer). A signature by your crew will not usually satisfy the Organisation! Explain to your witnesses that they are signing to say exactly where you landed and help them by filling in the appropriate section of the form under their guidance.
- f. The crew *must* book out with competition Control before leaving the site, even if they have been called out by the pilot by radio before he has landed.
- g. Once you and the crew are together phone control to say so and be sure to tell them if you plan to stop for a meal so that they do not have to wait up for you. They may advise you to book in the following morning.
- h. On booking in you will need to hand in:
  - (1). A landing point locator tracing. {plenty of time to fill this in when waiting for your crew}.
  - (2). Witness Certificate/Pilot's Claim form.
  - (3). Camera(s) - still sealed. You may be required by some organisers to photograph the official clock so do not rewind the film before going to Control. If Control asks you to remove the film for them make sure that it *is* rewound before you open the camera.
  - (4). Barograph - unopened, and/or logger. With mechanical barographs you are responsible for fixing and preserving the trace for at least 24 hours (End of protest period).

## COMPETITION DOS AND DON'TS

1. Read thoroughly the current **BGA Competition Handbook** and the **Local Rules**. It is probably true to say that if you fully understand these you will not put up a black at your first competition. However it is probably also true to say than no one **fully** understands them anyway, even the organisation!
2. Everything at a comps is **Time driven** and it is incumbent upon you to arrive on time. This applies from the initial booking-in procedure onwards. Do be at briefings by the announced time and aim to have your glider on the Grid at the appointed hour, however unlikely that the weather may look. A few prima-donnas turning up late and trying to shoehorn their gliders into their slots can cause mayhem.
3. Talking of booking-in you will need with you:
  - a. A BGA Registration form, completed beforehand. A bit of research is required as it asks for particulars of the glider which are only available by reference to the aircraft documents. (Weights, insurance details, radio licence renewal dates and the like).
  - b. A current BGA Competitor's Licence. Must be obtained beforehand from the BGA. (Fill in form with details of Silver C and send it in with the £10 fee and some passport size photos).
  - c. A current edition of the CAA 1/2 Million Air Map. (The organisers will initial yours to prevent fraud).
  - d. Camera(s) and loggers for sealing as required. (Make sure that you have set the date/time readouts correctly before you get to Competition Control).
  - e. Money for aerotow launch tickets. (The organisers usually specify the amount required in the **Local Rules**).
  - f. Names of crew and Next of Kin details for you and them.
4. Time on grid is usually announced over the Tannoy and earliest possible first launch time on the task sheet, which you will receive at briefing. Before launching, a startboard photograph must be taken at the glider, if you are using photographic evidence. An official will generally collect an aerotow ticket at the same time. Make sure that the aircraft is manned for this formality to avoid giving the comps officials a difficult time.
5. Be at you glider in good time for the first launch with the required water ballast on board and DI signed. Make sure that you have all of the paraphernalia with you: Tasksheets, Start point details, Cameras (start board photo done), Maps, GPS (programmed and on line), Barograph running, L-Nav altitude data entered and configured correctly, Food and drink stowed, Parachute inspected, Dark glasses and sun hat, Waterproof jacket, Money for phone calls, Telephone numbers, Pee bags. (Note: Do not take your car keys with you!).
6. Within 30 minutes of starting announce your callsign and start time on the Comp Frequency and receive an acknowledgement. (Note you can use another frequency and get your crew to inform control for you if you want it to be kept a secret).
7. Action after a competition landout is the subject of a separate handout. After a task completion you have a specific time to visit control with:
  - a. Cameras, still sealed. (Don't forget that you will be required to take another picture of the master clock at control before registering). Be sure that you wind back the film (under the supervision of an official) before opening the camera.
  - b. Barograph, still sealed if appropriate.
  - c. Logger.
  - d. Pilot's claim form, if required by the organisers.
  - e. You may be required to sign to say what you have left with control.
8. The following morning, do not forget to collect those items left with control.

# VARIOMETER SYSTEMS

## PURPOSE

1. The whole of soaring is concerned with extracting energy from the atmosphere and using it to fly high or fast and far. The ordinary airspeed indicator and altimeter provide measures of the kinetic and potential energy of the glider respectively, but the pilot also desires a direct, accurate and sensitive indication of the rate of change of energy. The variometer performs this function and is therefore an essential aid to the efficient operation of the glider.

## IMPLEMENTATION

2. The instrument measures the rate of change of atmospheric pressure in terms of rate of climb or descent. The instrument is in fact a sensitive vertical speed indicator and determines at any one moment the speed of air in vertical motion, or can be used to give an average rate of climb over a predetermined time scale. The rate of change of pressure is expressed to pilot in units per minute or second.

## UNITS

3. At present in the UK, the common unit of vertical speed is the KNOT which is a nautical mile per hour. The advantage of the knot is that calculations of time to gain or lose a certain height can be made very simply in conjunction with an altimeter calibrated in feet, since one knot is very nearly 100 ft/min. Another advantage is that as UK airspeed indicators are calibrated in knots, glide ratios can be calculated mentally when both vertical and horizontal speeds are in the same unit. However, it is an international convention in sporting aviation that flights for records and badges are reckoned in metric units, and consequently one tends to think of total flight distances in kilometres.

## THE VANE TYPE VARIOMETER

### Operation

4. One of the most popular types of mechanical variometers is the vane type manufactured by Winter (German) and PZL (Polish).

5. The vane variometer consists of a very accurately machined cylindrical chamber, which has a precision fitted vane mounted on jewelled bearings. The vane is directly connected to the scale pointer which is zeroed by a hair spring and balanced by weights. To minimise temperature error, the mechanism body is made of aluminium alloy with a bimetal compensator in the form of a bimetal strip operated valve. This compensates the vario for temperature errors by variable controlled flow of air to the chamber.

6. The principle of this type of variometer (Fig 2) is that air flowing to and from capacity is directed against the horizontally mounted vane, causing a deflection which will indicate a rate of climb or sink on a linear scale. Two calibrated tapered slots leak an increasing flow of air as the vane deflects further, until eventually the vane is balanced in a particular position for a given rate of climb or sink.

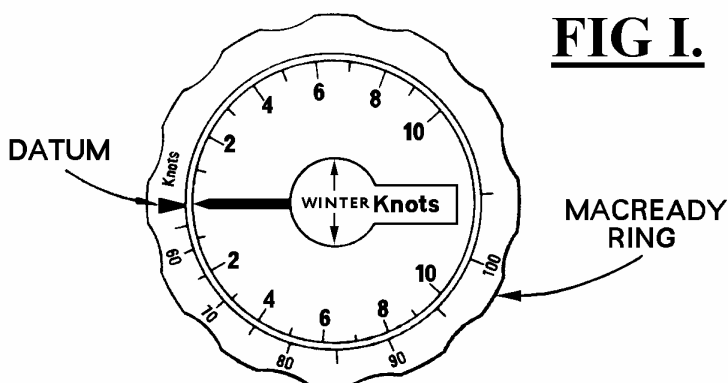

**FIG 1.**

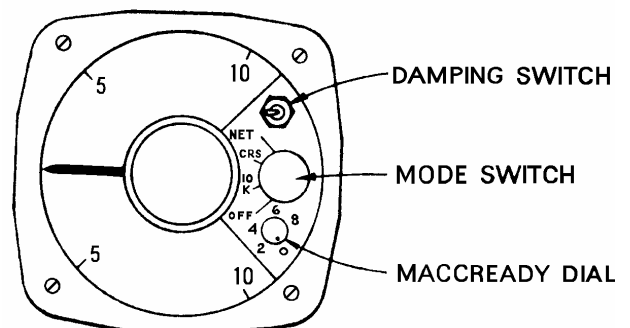

**FIG 2.**

### Capacity & Static

7. The capacity side of the Winter vario (Fig 3) is connected to a capacity flask of approximately 420 ml. The capacity flask is well insulated to avoid temperature changes in the flask. The static of the Winter vario may be connected to the Total Energy Probe. This provides not only a static source for the vario but also provides total energy correction.

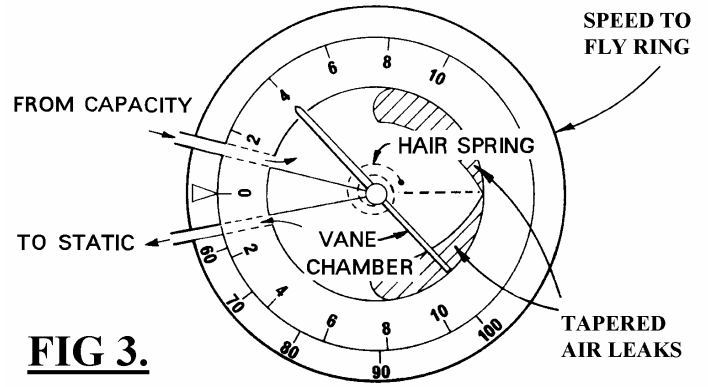

**FIG 3.**

**Fig 3. Layout of a Vane Type Variometer With Total Energy Probe**

### Errors

8. The accuracy of this instrument depends on the high standard of calibration which is set by the manufacturers. The calibration is made using the standard sea-level pressure/height relationship which gives negligible difference between indicated and true rates of climb.

9. This instrument is precision made to high standards, making it a very sensitive instrument with a very small time lag for a mechanical variometer.

### Pilot's Serviceability Checks

10. The pilot can do little to check the serviceability before flight beyond noting that the glass is intact and the pointer is at zero. Any deviation from zero by the pointer will cause the instrument to under or over read by that amount.

### **THE ALTITUDE DERIVATIVE VARIOMETER (ELECTRIC)**

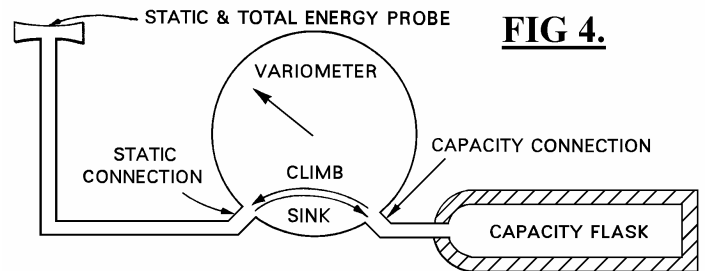

**FIG 4.**

11. The altitude derivative vario operates on the principle of generating a voltage directly proportional to altitude and taking a derivative of this voltage. Rate of climb is merely the derivative of altitude with time. In the heart of the vario are integrated circuit, pressure transducers, and operational amplifiers. The pressure transducer, is a tiny wafer of silicon which has a circular hole etched into it so the bottom side is about .001-inch thickness. The cavity is evacuated and a plate of silicon is brazed over it. A four-leg strain-gauge bridge is fabricated on top of this side. Atmospheric pressure from the outside puts stress in the thin strain section causing an unequal resistance change in the four legs of the strain-gauge. This millivoltage is then amplified, differentiated, further amplified, and finally drives a calibrated meter.

12. The more advanced altitude derivative vario's have a second pressure transducer which senses airspeed. This is then used for the netto, cruise mode and MacCready functions. The airspeed transducer can also be used for total energy compensation which is then integrated into the instrument making it unnecessary to have an external probe. One other advantage of this type of vario is that the rate of change of pressure is detected at source by the transducer, it therefore eliminates the need for an external capacity flask.

### Audio

13. Audio presentation systems are easily adaptable to the modern electronic vario's and can be integral with the vario or as a plug-in, separate unit. Audio presentation can be a simple UP/DOWN audible indication of lift/sink or the more advance, pre-set threshold system.

### Repeater Units

14. With two seater gliders the rear cockpit electrical vario is a simple repeater unit which merely displays what is shown on the front vario and indicates it both visibly and audibly.

### Modes Available

15. The more advanced electronic multi-function variometers use pressure transducers for sensing airspeed and altitude, and use the voltage derivative for rates of climb. On these instruments the pilot can select climb, Netto, Cruise, and MacCready functions, and select the appropriate damping. This type of vario is very compact, with self contained capacity, T/E compensation, and a plug in audio system.
16. The glider polar and MacCready function are individually calibrated into each instrument making it unnecessary to have external capillary leaks or valves.

### Using Cruise

17. To use cruise in the air, set the MacCready to the expected thermal strength, or zero if best range is desired. Then to maintain the best cruising speed hold a zero reading on the vario. To achieve this pull back and fly slower when the vario reads up and push forward to increase speed when the vario reads down.
18. The advantage of Cruise over Netto is that in maintaining best cruising speeds it is only necessary to monitor one instrument. This is helpful in minimising flying fatigue, allowing maximum concentration on searching for the best conditions ahead.
19. A word of warning; Cruise mode is not a substitute for the Airspeed Indicator. It will often direct you to slow down stalling speed, or fly faster than the red line in strong sink.

### Theory of Cruise

20. The only difference between basic Netto and Cruise Control is that the cruise control capillary or circuitry is sized to leak at a rate proportional to the optimum speed to fly instead of the glider's polar sink. The expected thermal strength dial merely shifts the vario zero position downwards in the same manner as rotating a speed to fly ring up for greater expected thermal strengths.
21. In this cruise operating mode any undirected increases of airspeed will make the vario read up, and a decrease in airspeed will cause the vario to read down. Likewise, any changes in airmass will cause a direction to decrease or increase speed depending whether it is rising or sinking air.

### Ground Test

22. To ground test the vario, turn the vario switch from off to the position. The vario should indicate zero after a finite warming-up period. Turn the vario switch to NET position and the meter should read approximately 3 knots down with the MacCready setting on zero. Larger inputs of MacCready should deflect the vario further downwards by the amount indicated on the dial setting.
23. When carrying out the ground check on the vario the audio may be switched on, and with the pointers on zero the up and down audio indications can be checked.

## **THE 'NET' VARIOMETER**

### Introduction

24. In the 1950's a Dr Paul MacCready not only introduced the speed to fly ring, but proposed a system to cancel out the polar sink of the glider. The 'Net' result of this was that the indications of the variometer became an indication of the true vertical speed of the air surrounding the glider. Hence such variometer became an instrument which read true vertical Air Mass movement, irrespective of the gliding angle (polar sink).

### Purpose

25. Initially the idea did not catch on simply because it was conceived for use whilst circling in a thermal. At that stage, the rate at which the glider is climbing is of more use to the pilot than information about the air mass movement alone. Only with the advent of higher performance gliders which could make use of thermals without needing to stop and circle, could the concept be fully exploited.

26. With the rapidly improving performance of the first generation GRP gliders in the late 60's and early 70's, the Air Mass reading variometer was reintroduced. It was modified for use with a modern total energy system and could now be used for cruising flight. As glider performance increased so did the speed and distance which gliders could be cruised between thermals. Thus the need for rapid detection of rising air and an early indication of the thermal strength became paramount if the pilot was to make the best use of the energy available.

### Using The Netto Variometer

27. The Net or Netto variometer, as it is commonly called, subtracts the glider's polar sink from the vario reading; so the resultant reading is the vertical motion of the air itself. So when cruising fast between thermals it is much easier to judge the thermal strength before slowing down. The pilot can therefore spot the gently rising air even when flying fast, and slow down accordingly. Speed ring flying is much simpler because the variometer, ignoring the glider's sink, is not prone to differing sink rates as airspeed alters. The vario needle therefore does not have to be chased as speeds change.

28. On strong thermal days, 'Dolphin flying' (the art of climbing and diving in the energy) comes into its own using the Netto system. It is easier to 'see' the structure of the thermal as you fly into it and gives a vital few seconds warning as you approach the core. At 100 knots you travel 330 ft in two seconds and without the advantage of Netto, the best lift could be passed before deciding to slow down.

29. A word of warning! Netto has been known to induce a state of euphoria as the vario sits happily at zero for minute after minute. Remember that the altimeter is quite unaffected by such goings on and you could be lower than you thought.

### Theory Of Netto

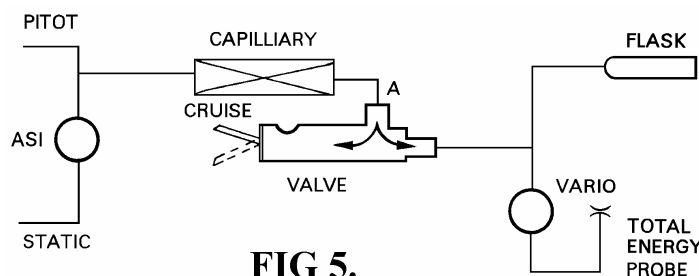

**FIG 5.**

**Fig 5. Netto Installation Layout**

30. The capillary leak aims to supply the air needed to maintain pressure equilibrium in the vario flask as the glider flies downhill (polar sink). At cruise speeds of 60 - 100 kts the rate of sink is very nearly proportional to the square of the airspeed. The flow of air through the capillary increases at the same rate to provide an equal compensation for the outflow from the flask due to polar sink. The 'Net' result in smooth air will be for the vario to read almost zero when flown at between 60 - 100 kts. At speeds below 60 kts the sink rate leaves the square rule because of induced drag increasing sharply. The leak cannot supply sufficient air to keep capacity accurately compensated and merely reduces the sink readings by an arbitrary amount - 1 kt at thermaling speeds.

31. The calibration is made for a specific wing loading. So where a glider has the capability of carry water ballast, it is usual to fit a second leak to compensate for the different polar performance, with a change-over switch to select wet or dry. It is also necessary to recalibrate the speed to fly ring to reflect the new optimum speeds to fly without polar sink, and whether wet or dry.

NOTE: The valve is not a simple ON/OFF. Input Part A vents to cockpit when in a climb so that the airflow is established in the capillary at all times. This reduces change over lag by some 2 seconds.

### **TOTAL ENERGY - THE IRVING TUBE**

#### Purpose

32. Success in soaring depends on efficient energy management, both when climbing and cruising. A total energy variometer is therefore an essential feature of modern glider instrumentation and it is only by its use that the technique of dolphin flying is made really feasible. The simplest and one of the most effective ways of achieving total-energy in most types of variometers except the complex, multi-function types, is by connecting the 'static' side of the instrument to a source of suction, the suction being equal to the dynamic head of the airstream. Such a device, when accurately calibrated, is inherently correct at all heights and its function is independent of the characteristics of the variometer itself.

33. The standard variometer simply indicates the rate at which the glider is gaining or losing altitude. This would be quite satisfactory if the glider were flown at a constant airspeed. However, it is possible, by diving to gain speed and then climbing so that the speed falls back to the original figure, to make the variometer show climb during the zoom when in fact the air is not rising; the glider gains nothing, it merely exchanges excess speed for height. In other words, during the zoom it is translating kinetic energy (speed) into potential energy (height). Because the air is not rising, there is throughout this exchange a loss of Total Energy.

### Irving Tube

34. The Irving Tube may either fin or fuselage mounted as shown in Fig 6, and will supply Total Energy compensation for more than one variometer at a time.

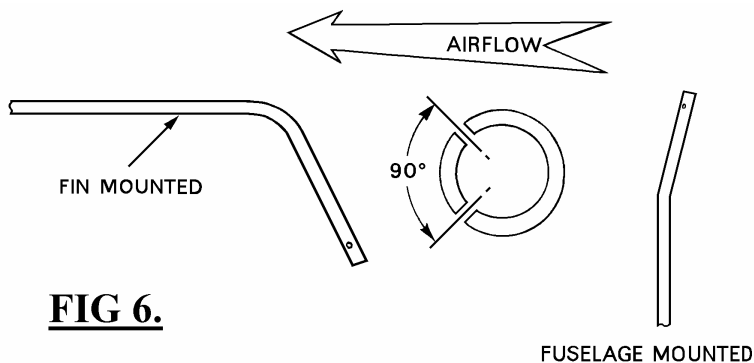

**FIG 6.**

**Fig 6. Irving Total Energy Tube**

### Implementation

35. If the variometer is made to take into account the changes in kinetic energy as well as in potential energy it would indicate the loss of total energy ie, it would eliminate the variations caused by speed changes ("stick thermals") and show, in still air, the rate of sink of the glider for the airspeed at that moment. In the same way, in a thermal, the actual rate of climb would be shown, unaffected by speed variations, thus allowing accurate and rapid centering in the thermal.

### The Total Energy Tube

36. The variometer is converted to total energy indications by connecting the static side of the instrument to a probe mounted in the slipstream. The suction at the total energy head is related to the airspeed - an increase in airspeed causes increased suction - and the probe is so constructed that the suction at a given airspeed is equal to the "dynamic head" ie the pressure difference between the static and pitot tubes of the airspeed indicator.

37. At a steady airspeed in still air dynamic head remains constant, the ASI showing a steady reading and the suction in the probe being steady. But the glider is sinking and the static pressure increasing and despite the suction at the probe, air is flowing into the variometer. The rate of sink shown by the instrument will therefore be the glider's actual rate of sink through the air at that moment.

38. Assume now that the nose is lowered to increase the speed from 50 to 60 knots and consider the pressures being applied to the variometer static connection at a speed, of, say 55 knots. The sinking speed in this case is a little greater than it would be at a steady speed of 55 knots since the glider is diving to increase speed further. The pressures at the static connection will be:

- a. A static pressure increasing at a rate corresponding to an airspeed of 55 knots.
- b. An additional rate of increase of static pressure because the glider is diving a little.
- c. A suction, increasing because the airspeed is increasing.

39. The increasing pressure (b) and the increasing suction (c) cancel out, leaving only (a) so that the variometer shows the rate at which the glider sinks at a steady speed of 55 knots.

40. Similarly, when the speed has fallen to 55 knots in the following zoom, the pressure at the static connection will be:

- a. A static pressure increasing at a rate corresponding to an airspeed of 55 knots.
- b. A decrease in static pressure because the glider is climbing.
- c. A suction, decreasing because the airspeed is decreasing.

Once again, (b) decreasing pressure and (c) decreasing suction, cancel out, leaving the rate of sink at an airspeed of 55 knots.

41. When the speed is varying between 50 and 60 knots, the variometer readings will lie between approximately 130-160 feet/mins, a much smaller range than would be shown by a variometer without TE which could be reading as much as 300 feet/min down at 55 knots in the dive. This would, in fact, be more nearly the actual rate of sink at that instant but such information is of less use to the pilot than that given by the Total Energy Variometer which eliminates the effects of changing airspeed. The greatest advantage will be found in a thermal when the Total Energy Variometer shows the actual vertical speed of thermal less the rate of sink of the glider at the indicated airspeed the pilot is trying to maintain.

#### Airspeed

42. The accuracy of the total energy head is most important. Too little suction, and the variometer shows "stick thermals"; too much, and the opposite occurs - a pull-up manoeuvre shows a marked sink reading. (It is important to remember that there is a genuine effect due to "g" which can be mistaken for over-compensation; at the beginning of a pull-up, the extra load factor increases the induced drag and a total-energy variometer will show more sink, or less climb, typically by 0.5 - 1.0 knots. The converse effect will occur during push-overs). Also, the suction must be insensitive to the airflow direction up to quite large angles of incidence or sideslip, so that the instrument reading is unaffected by gusts.

43. The probe is prone to icing and it is therefore advisable to fit an extra pneumatic switch into the system so that the variometers may be changed to the normal static source should they be rendered inoperative by icing. They will of course revert to uncompensated indications in this mode, but this is preferable to having no variometers at all.

## ABOUT THE L-NAV

1. The L-NAV is a comprehensive audio variometer and glide computer, developed especially for the cross country pilot, but it is ideal for soaring of all types. It has sensors for altitude, Rate of Climb (Variometer), Airspeed, and Vertical acceleration. Variometer information is displayed on a normal miniature analogue variometer by means of a pointer against a scale. Variometer information is also communicated via straightforward Audio Tones. Finally the rate of climb/descent is averaged over 20 seconds and presented digitally at the top right hand corner of the liquid crystal display, when the **Main Screen** is selected. The L-NAV is programmed with the sailplane performance data (Polar Curve). If the average achieved rate of climb is manually entered on the Main Screen (**MacCready** or '**Mc**' value), speed-to-fly is calculated automatically and presented graphically by means of a **Push-Pull** indicator on the left side of the **Main Screen**. Speed-to-fly errors are also communicated via easily interpreted **Audio Tones**.

2. Because the L-NAV knows airspeed, it can keep track of the distance flown. It works just like a motor-car speedometer and odometer except that it can count down as well as up. The L-NAV also knows its altitude, and so can convert Indicated airspeed to True airspeed. An estimated head or tailwind can be entered, thus yielding ground speed and therefore the distance flown. Since it knows the polar for the glider it can work out the altitude needed to fly a known distance. As the distance-to-go counts down, the altitude required is re-calculated and is continuously updated on the **Main Screen**. The difference between the altitude required and the known barometric altitude is shown graphically by means of **Glide Slope Bars** on the right hand side of the **Main Screen**.

3. If you stop to circle in a thermal, a built-in G-sensitive switch detects the increased wing loading and turns off the distance accumulator until straight flight is resumed. This is confirmed by the **Push-Pull** indicator being turned off. An external **Hold-Cruise** switch on the panel does the same thing and is used if you choose fly at right angles to the track. The distance accumulation due to wind drift is maintained during circling flight.

4. The unit can be connected to a **GPS** receiver. In this case navigation becomes simpler and more accurate since the distance to the goal is inputted precisely by the GPS, and the L-NAV computes the wind drift with the aid of the GPS-derived ground speed.

### CONTROL RULES

- \* Press LEFT or RIGHT Arrow key to move to a new Screen
- \* Press UP or DOWN Arrow key to change a Value within a Screen. Values change slowly at first then more rapidly. This enables a quick selection of even quite large figures.
- \* Press GO to return to the Main Screen

### THE L-NAV DISPLAY SCREENS

5. Referring to **Fig 1** the number of display screen options can seem somewhat daunting at first but fortunately the unit always returns to the default unballasted, clean polar when first switched on. To use it simply as a variometer, merely turn the **ON/OFF/VOLUME** knob clockwise to give a suitable audio volume. You will see '**L-NAV V3.0**' for several seconds, then the Altimeter Setting screen appears. Using the **UP** or **DOWN** arrow keys, just set zero or airfield elevation for QFE or QNH operation as you wish, then press **GO**. This will display the **MAIN SCREEN** and the instrument is ready for use as an audio variometer. Whichever screen is currently being displayed, pressing **GO** always returns you to the **MAIN SCREEN**.

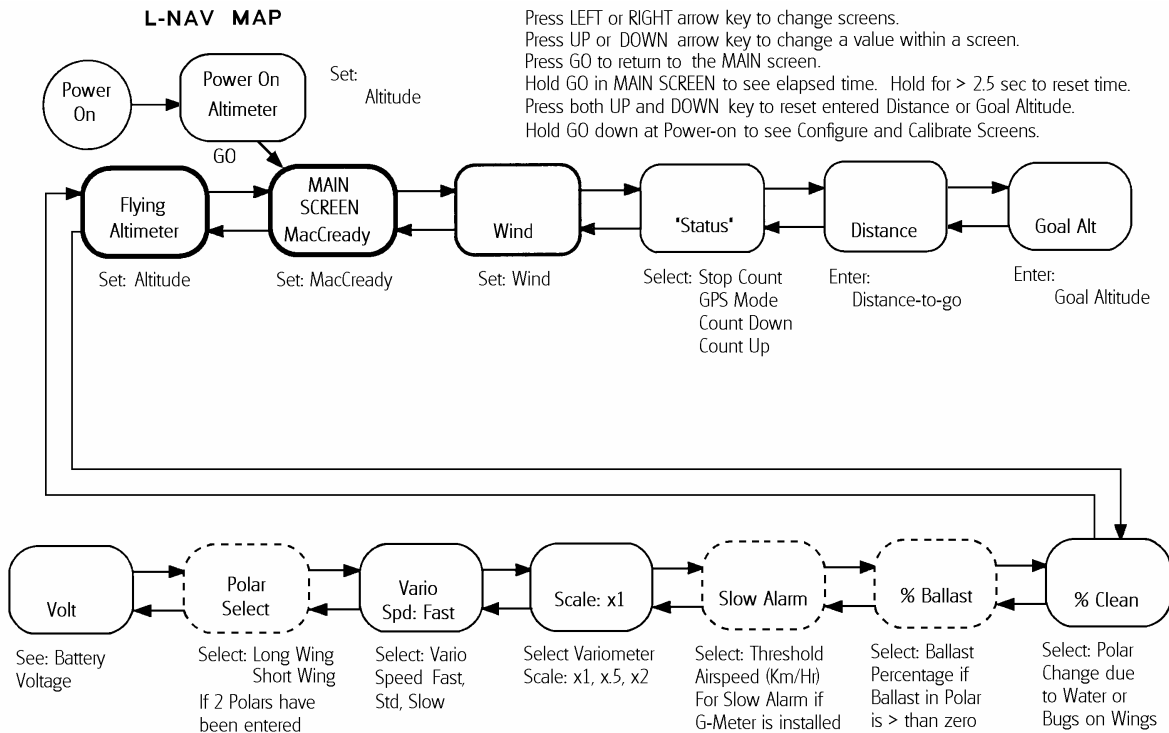

FIGURE 1

6. **MAIN SCREEN.** Referring to **Fig 2**, from top to bottom the numbers are:

- 20 second average of the Variometer Reading
- Distance-to-Go
- Altitude Required
- MacCready Number, Head/Tail Wind

7. When the **GO** annunciator at the top of the screen is on in flight, the instrument will count distance. The **PUSH/PULL** graphic is present indicating that the instrument is in 'CRUISE' mode. When the instrument is in 'CIRCLING' mode, the speed-to-fly graphic disappears, the distance accumulation is held and the audio tones are altered.

8. **Inserting the MacCready (Mc) Value.** Confirm that the **Mc** is underlined by a cursor. (Use the Left key to move the underline from **W** to **Mc** if necessary) . When the UP arrow is pressed the Mc value is increased in 1/2 knot increments and vice versa with the DOWN arrow. An increase in MacCready value demands a higher flying speed and more of the PUSH speed bars will light to confirm this.

9. **Inserting Head /Tail Wind Component.** Pressing the RIGHT arrow key moves the cursor to the right to highlight **W**. Now the UP/DOWN arrows can be used to change the estimated wind (**HW**= Headwind; **TW** = Tailwind).

10. **Display of Elapsed Flight Time.** Holding down the GO key when in the MAIN SCREEN displays the elapsed flight time. The timer resets if the key is pressed for longer than 3 seconds. The timer only counts if the airspeed is greater than 25 knots. Time is automatically reset when the glider starts a flight, so that after landing it will display your total flight time.

11. **STATUS SCREEN.** This is the screen immediately to the right of the one used for setting the head and tailwind wind. The Status screen is used to start the count down for a previously entered distance-to-go or to start counting up the distance away from a point, to stop the distance count (In which case the **GO** annunciator on the **Main Screen** is turned off), or to select the **GPS Mode** if a GPS unit is connected to the instrument.

12. **DISTANCE SCREEN.** The final glide distance is entered on this screen by means of the UP and DOWN buttons. Altitude required is also displayed on this screen. Altitude Required = Goal Alt + predicted altitude loss over the distance-to-go.

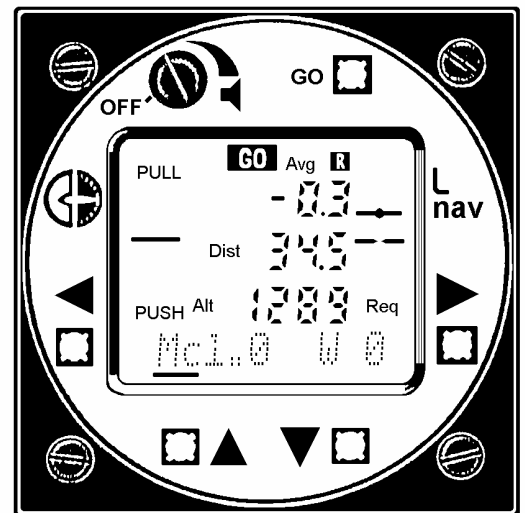

FIGURE 2

13. **GOAL ALT SCREEN.** Use the UP and DOWN keys to enter the Goal Altitude you want when you arrive at the goal. It is the airfield elevation plus the circuit height required. (Or just the circuit height required if flying on QFE).
14. **ALTIMETER SCREEN.** This is just to the left of the Main Flying Screen and may be reached in 2 ways: firstly by 5 presses of the left button, or, (remembering that pressing GO takes you straight to the Main Screen), by pressing GO once and LEFT once. This screen displays the Altitude and Barometric pressure and the UP /DOWN keys are used to set the altimeter.
15. **PERCENT CLEAN SCREEN.** Just to the left of the ALTIMETER SCREEN is the % CLEAN SCREEN. This enables you to degrade the anticipated performance as you collect bugs on the leading edges. A good rule of thumb is to count the flies along a metre of the leading edge and call this the percentage of bug deterioration. Eg; 10 bugs per metre equals a 10% performance defect and so on.
16. **PERCENT BALLAST SCREEN.** To the left of the % CLEAN Screen is the % WATER BALLAST SCREEN. Provided that the initial configuration has been correctly carried out, the instrument knows the dry weight of the aircraft and crew and the water ballast capacity of the glider. Simply punch in the percentage of the total ballast capacity you have put in the tanks and the polar will be automatically adjusted to suit.
17. **OTHER SCREENS.** Most of the remaining screens to the left of the Altimeter screen are "switches" which let you choose the operating parameters of the Aircraft or the Instrument. A screen bounded by a pecked line is only used if that particular parameter is variable. A variometer scale of x2 means that the full scale of the instrument is 20 knots and so on. Variometer scales of other than x1 are noted by annunciators at the top right of the Main Flying Screen. The '**Spd: Fast**' screen lets you select the response of the variometer, the fastest being about 0.5 seconds. The audio range and response are also factored to match the meter.
18. **'RELATIVE' OR 'SUPER NETTO' VARIOMETER.** Above the **averager** on the Main Screen a letter '**R**' illuminates at higher speeds as the vario switches to "Relative" or "Super Netto". Below the sailplane's best glide speed the vario indication will be the same as an ordinary Total Energy Vario. During cruising flight at above the best glide speed, the **R** annunciator is lit and the Relative Vario will indicate the rate of climb or descent which you would have if you slowed to circling speed. This helps you to evaluate the lift, even when cruising fast. The transition speed increases at a higher wing loading. The "Relative" variometer is an improvement over the normal "Netto" variometer because the pilot does not have to mentally subtract the polar sink rate to estimate the rate of climb he would achieve if he stopped to circle in the thermal. Note however that whilst this is happening, the Averager always shows the actual rather than the "Relative" rate of climb or sink of the sailplane.
19. **AUDIO.** The L-NAV has a variety of tones and patterns to help you climb or cruise better. It will take a little time to get used to them but remember that the pitch (frequency) of the Audio is always proportional to the variometer indication. A higher pitch means a faster climb rate. The audio tone is switched on and off by the L-NAV and the tone patterns signify different flight conditions as follows:

FLIGHT CONDITION	tone pattern	COMMENTS
Climb rate less than MacCready setting	50% on, 50% off	The climb pattern is heard any time the vario is above zero.
Climb rate higher than MacCready setting	75% on, 25% off	This is true in both climb and in circling modes
Circling (Climb) mode. Vario indication less than zero.	Silence if configured for No Sink Tone; otherwise, continuous tone	The default setting is for No Sink Tone
Cruise mode; near correct speed-to-fly	Silence	
Cruise mode; flying below optimum speed	Dit-Dit---Dit-Dit--- "Speed up---Speed up!"	In the default configuration, the Speed-Up or Slow-Down tone pattern begins when 2 bars show on the Speed-to-fly bar graph
Cruise mode; flying above the optimum speed	Continuous tone "Sloooow Dooooown!"	
Airspeed drops below Slow Alarm Threshold in either cruise or circling mode	Dit-Dit---Dah	The threshold airspeed goes up as the wing loading increases. This feature is only available with the optional G-Meter fitted.

**OPERATION WHEN CONNECTED TO A GPS RECEIVER**

20. A GPS receiver picks up signals from a set of satellites orbiting the earth and calculates its position in 3 dimensions (Latitude, Longitude and Altitude) with great precision. This information is updated at 1 second intervals, enabling the device to compute speed and direction of travel (The Track) over the ground. If the pilot inputs a goal location in Latitude and Longitude, the GPS receiver calculates distance and bearing to that goal from the current location. When the GPS is connected to the L-NAV, this information is fed to the instrument and removes the uncertainty of the "Dead Reckoning" estimations normally used. The wind component in the direction of flight to the goal is computed precisely, and this is critical in calculating the altitude required. The distance to the goal is known at all times even if excursions off track are made. The combination of accurate wind and distance means an accurate estimation is possible of the altitude required for a final glide. The GPS receiver must be configured to output **NMEA 0183 version 2.0** in the **NONE/NMEA** field, in order to interact with the L-NAV and the EW Logger facility.

21. **SCREEN CHANGES WHEN GPS MODE IS SELECTED.** Fig 3 shows how the Screens change when **GPS Mode** is selected from the **Status Screen**. Functions to the left of the **Wind Screen** are unaffected. The **Wind Screen** now gives the choice of Automatic "A" or Manual "M" wind for the **Main Screen**, selectable by means of the UP and DOWN keys. For an accurate wind measurement you must fly at a constant airspeed and track for at least 5 seconds. Also the altimeter must be referenced to Sea Level (QNH) since True Airspeed differs from Indicated Airspeed by 4% for each 1000ft increase of altitude. If the altimeter is set to QFE at a 1000ft altitude airfield, at 70 knots a false 3 knot headwind would be displayed.

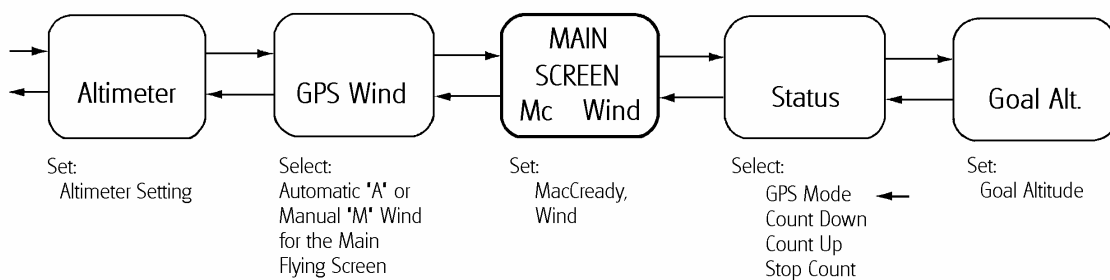

FIGURE 3

22. Updating of the L-NAV Final Glide wind estimate is suspended if Track Error is greater than 20 degrees, if Track is changing at greater than 6 degrees per second or if the L-NAV is in circling mode. When updating is suspended, the **Main Screen** wind annunciator changes from upper case to lower case. When no wind information is available the Altitude Required number is replaced by dashed lines. The status of the Wind computations on the **Main Screen** is as shown below:

<b>Mc1.5 HW12</b>	Automatic Wind	Updating
<b>Mc1.5 hw12</b>	Automatic Wind	Updating suspended
<b>Mc1.5 w--</b>	Automatic Wind	No wind information available
<b>Mc1.5 HW12</b>	Manual Wind Entry	(Choose Manual in the GPS Wind Screen)

23. The **Distance Screen** is disabled in GPS Mode. Since the GPS computes the distance and bearing from your current position to the Goal, there is no requirement for the pilot to enter distance-to-go. The L-NAV displays the Distance-to-go in the middle of the **Main Screen**. If no waypoint has been selected, or if the GPS is not getting position fixes, dashed lines replace the computed value.

24. **TRACK ERROR DISPLAY ON THE MAIN SCREEN.** The GPS measures the **Track** (the actual direction of travel over the ground). This is more useful than compass heading since drift is taken into account and when the track coincides with the bearing to the goal then you are flying directly towards that goal. The L-NAV displays the Track Error (Defined as Bearing minus Track) at the upper left of the **Main Screen**. Track error is replaced by a Dash when the number is greater than 90 degrees or when the Bearing or Track is undefined. Track Error is also shown on the **Altimeter** or **GPS Wind** screens. A minus figure requires you to turn left by the number of degrees shown to regain the correct track and a positive figure requires a right turn.

## FLYING WITH THE L-NAV WITHOUT THE GPS INTERCONNECT

25. DECIDING THE MACCREADY VALUE. (For changing the value refer to para 8). According to the theory developed by MacCready, 'Mc' should be set to the average rate of climb expected in the next thermal. The average must take account of the time spent in entering and centring in the lift and is usually much less than the peak averager reading seen during the best part of the thermal. If you observed a peak on the averager of 4 knots during part of the thermal, a good estimate of the theoretical MacCready value might be 2 to 3 knots. Often, experienced pilots will set an even lower value than this - perhaps to only 1 knot under the above circumstances. The penalty for flying too slowly between thermals is very low, in terms of average speed achieved, and is usually outweighed by the greater cruising range. This, in turn, gives the opportunity to pass up a weak thermal in favour of a more distant but stronger one. Under certain conditions it may pay to set the 'Mc' to zero and attempt to go cross-country without stopping to circle.

26. FINAL GLIDE WITHOUT GPS. To use the L-NAV for a final glide it must know the Distance-to-Go. Here is an example:

a. You are 35 nautical miles away from the airfield. The Airfield elevation is 500ft AMSL and you want to arrive with 500ft in hand for a circuit. There is an estimated headwind of 5 knots. Enter a goal altitude of 1000ft, a distance of 35.0 miles, and HW=5. With the inbuilt 'default' polar, you should see a required altitude of 6860ft at Mc=0. Increasing the value of Mc, increases the altitude needed because you will cruise faster and have a poorer glide angle.

b. When first switched on, the L-NAV is in its **Stop Count** state. To start the distance count down press the Right button once or twice (Depending upon whether 'Mc' or HW is underlined) to go from the **Main Screen** to **Status Screen** and select **Count Down**, using the UP/DOWN keys, then press **GO** to return to the **Main Screen**.

c. Proceed with the cross country and you will notice that the altitude required decreases as you get nearer to your goal. Assuming that you did not have enough height to begin with, just carry on normally, stopping to thermal when appropriate, until the glider's altitude matches the **Altitude Required**, then you may begin your final glide.

d. The graphic Final Glide display shows your altitude relative to that required. The altitude difference corresponding to each bar depends on distance: at 15 miles out, each bar equals 200ft; at 30 miles each bar equals 400ft.

e. If you encounter lift en-route, you will find yourself above the glide path. This means that you can glide faster and still reach the goal at the height you specified. Using the arrow keys highlight 'Mc' and increase the value until the glide path display is centred. At the higher MacCready setting the speed to fly is increased to allow for the extra height. Conversely, if you encounter sink en-route, you will need to reduce the 'Mc' setting to centre the glide slope display, or find some lift.

27. ESTIMATION OF ALTITUDE NEEDED WHEN FLYING AWAY FROM BASE WITHOUT GPS. As you leave the airfield on a cross-country, the L-NAV will display the altitude needed to return to the field, provided that you select **Count Up** on the **Status Screen**, then **GO** to return to the **Main Screen**. You will observe that the Altitude Required increases as you go further from the airfield. The effect of wind on Altitude Required is different in Count Up mode than in Count Down or Stop Count modes. If you leave with a tailwind, then the altitude needed to return must be calculated with an equivalent headwind. When you switch from **Count Up** to **Stop Count** or **Count Down**, you will note that the Altitude Required changes because it is calculated with actual rather than reversed wind. Although selecting Count Down will correct the Altitude Required for you automatically you will need to allow for the increase in Altitude Required if you are operating downwind of the site and always intend to be within gliding range.

28. CORRECTING THE WIND ESTIMATE ON A FINAL GLIDE WITHOUT GPS. The total ground distance covered is the sum of the air distance and the wind effect. The L-NAV stores each component separately and displays the sum. Distance flown due to the wind is recalculated if the pilot inputs a change in distance. It is also reset if the status is changed from **Stop Count** to **Count Down** or **Count Up**. The distance due to the wind is the product of the wind estimate (**HW** or **TW**) and elapsed time. The wind estimate may be changed at any time, and provided that enough time has elapsed since the last reset of wind distance, you will see the distance change as you alter the estimated wind. This feature can be used to improve the accuracy of the wind estimate and thereby improve the estimate of the altitude needed to final glide. This is best explained by means of an example:

a. Consider a 20 mile glide in still air at 60 knots airspeed. After 10 minutes the glider will be 10 miles from goal. Assume that you had mistakenly entered a 6 knot headwind at the start of the glide. After 10 minutes the L-NAV will have accumulated minus 1 mile of wind distance so that the display will show you as 11 miles from base. If you now alter the wind estimate until the distance-to-go shows the correct value of 10 miles, the wind estimate will now show 0 knots and you have corrected the wind estimate.

b. Of course you could have corrected the distance-to-go from 11 to 10 miles via the **Distance Screen**, but this would still leave you with the incorrect wind estimate! Naturally, modifying the **Distance Screen** value, or changing the count status, resets the accumulated distance flown due to the wind back to zero, since you are inputting your actual range from your goal.

c. For an accurate reassessment of the wind estimate, a significant time must elapse between checkpoints, so they will need to be at least 5 miles apart.

### **USING THE EW BAROGRAPH**

1. Forget about bits of tinfoil and messy smoked drums, or finding some paper tape and an Official Observer (OO). The EW Barograph has changed all that! It is a self contained unit that will slip into the side pocket of your glider. It is tamper-proof and thus needs no sealing. You only have to convince an OO that it was the one used on your badge flight and print out the trace in his presence. The print-out has spaces for the OO to fill in your details and sign it. You have the choice of printing the trace as a graph or as a list of heights versus time or indeed both of these options. The unit may also be connected to a GPS unit when it will log position information as well as height.

2. The accompanying pictures show the rear and front of the EW to full scale. On the rear you will see the battery compartment. The unit runs from a single 9 Volt PP9 battery that will provide a whole season of moderate use. The switch-on procedure and other important information concerning operation of the unit are summarised on the back too. On the front is a liquid crystal display (LCD) window and a Key Pad.

3. During the switching-on procedure the EW Barograph prompts you to check, and perhaps to enter, the following important items:

a. The date in years, months and days.

b. The time in hours and minutes.

c. The user number associated with the trace. (This could be the numerical part of your personal callsign or the Aircraft Identification).

d. The time interval between height samples in seconds. (The unit's default setting is 30 seconds).

4. During the switching-on procedure, the unit will automatically turn itself off again after 30 seconds if no button is pressed in the meantime. This is to prevent accidentally switching on the unit and flattening the battery when it is not in use. To switch on the following sequence must be used:

a. Press **ON**; "d" (date) will appear for a moment and the barograph will then show the year on the display. If this is incorrect, just enter the last 2 digits. (The century is set automatically by the barograph). When the year is correct press **ENT**.

b. The display will then show the month and day. (Month first). If the display is incorrect enter the right ones using the key pad. Include the leading zeroes if the day or month is less than 10. When correct press **ENT**.

c. "t" (time) will momentarily appear, then the display will show the time in 24 hour format. Use the keypad to adjust this if necessary then press **ENT** again.

d. "U" (user number) will flash up followed by the previous user's number. Any number from 1 to 9999 may be inserted at this point before pressing **ENT** again.

e. "Int" (sampling interval) will briefly appear followed by the default time of 30. This is usually suitable for most purposes and provides a graphical output which resembles that of a Winter Barograph. A 10 second sample rate gives a more detailed trace but will cut down the time before the memory is full. As a rule of thumb, the unit will store about 30 hours of data at a 30 second sampling rate and 10 hours at a 10 second rate, provided that the memory has been cleared of previously stored traces at the outset. Once the sample rate has been set press **ENT** for a final time and the unit will be recording pressure altitude at the set sampling rate. A small red light emitting diode (LED) alongside the LCD will flash every second to give a visual indication that the unit is recording. The LCD will continuously display the most recent recorded height in decimal kilometres.

5. The only way to switch the instrument off is to press the sequence **ON OFF OFF**. This effectively guards against inadvertent switching off by careless handling.

6. In flight you may wish to mark a particular point of interest. This is called “tagging” the trace and it appears as a vertical line on the graphical trace, or a height + time on the numerical printout. You can tag the trace at a particular point from the keypad and assign any number from 1 to 9999. To do this:

- a. Press the **ON** key to activate the keypad (the LED will remain on).
- b. Enter the number of the tag.
- c. Press the **TAG** key.

The display will briefly show “taG” then revert to normal height indications. If no number is entered, 0 will be used to signify the tag. When trying for a height gain it is useful to “tag” your trace immediately after your launch as you can later call up the height gain in metres above the lowest point after your last “tag” to confirm that the badge requirement has been exceeded.

7. To show the height gained it is necessary to “Activate” the keypad with the **ON** key then press **3 ALT**. The unit will still be recording the *normal* flight data during this procedure and you can return to the altitude indication at any time by pressing **ON** then **ALT**.

8. To clear the memory of all previous traces, start with the barograph turned off:

- a. Press **ON** and wait for the year to be displayed.
- b. Press **ALT** and the display will show “CLER”.
- c. Press **TAG** and the display will show “SURÉ”.
- d. Press **YES** and the display will show “donE”.

9. Battery power may be checked any time the unit is operating by pressing **ON** to activate the keyboard, followed by **3 TIME**. The acceptable working range is 300 to 500. A fresh battery should show approximately 500. If it shows below 300 then it must be changed. To return to normal altitude readings press **ON ALT**.

10. When changing a battery it is advisable to discharge the capacitors in the unit by dabbing a damp finger across the battery plug terminals for a few seconds. If this is not done the unit may go into strange error modes during a battery change. This technique will generally sort out spurious error messages that may occasionally occur if the unit is subjected to strong Radio Frequency (RF) transmissions, etc.

11. To print a trace:

- a. Connect the unit to a compatible printer with the approved connecting lead.
- b. Switch on the printer and confirm that it is “on line”.
- c. Press **ON** followed, when the year is displayed, by **PRT**.
- d. Thereafter, follow the printed instructions.

